



# KOGAN SMARTERHOME™ LX6 ROBOT VACUUM CLEANER

KAVACRBL06A & KAVACACL06A

Contents	<b>2</b>
Safety & warnings	<b>3</b>
Components	<b>5</b>
Overview	<b>6</b>
Before first use	<b>8</b>
Connect to SmarterHome™ app	<b>11</b>
Operation	<b>15</b>
Cleaning & care	<b>20</b>
Google Home control	<b>25</b>
Amazon Alexa control	<b>28</b>
Specifications	<b>31</b>
Troubleshooting	<b>32</b>
Notes	<b>35</b>

# SAFETY & WARNINGS

## Usage Limitations

- This product is designed for floor cleaning in a home environment only and cannot be used:
  - Outdoors, such as open terraces.
  - On irregular or soft surfaces, such as a sofa.
  - Commercial or industrial environments.
- Do not use the product in elevated areas such as a penthouse, an open terrace or furniture top that does not have a protective fence at the robot's height.
- Do not use the product at a temperature of above 40°C or below 0°C or when there are liquids or sticky substances on the ground.
- Remove cables from the ground before use to prevent damage to the robot and other items.
- Clear fragile objects such as vases, plastic bags, etc. from the ground to avoid damaging items and the vacuum.
- People with a physical or mental impairment should not use or operate the product unless they have been given instruction to do so safely and understand the products manual entirely.
- Children should not use the product. Please keep children and pets away when the device is working.
- Keep the main brush and other cleaning tools out of reach of children.
- Do not place objects, including children and pets, on the machine.
- Please keep hair, fingers and other parts of the human body or pets away from the suction inlet when the machine is working.
- Never allow the vacuum to come into contact with hot or burning items such as cigarette butts.
- Do not use the product to clean long-haired carpet (some dark carpets may not be cleaned normally).
- Prevent the vacuum from suctioning hard or sharp objects (broken glass, iron nails, etc).

- Do not move the machine by holding the protective cover of the laser distance sensor or collision bumper.
- Only clean or maintain the vacuum and the charging base while it is in a power-off state.
- Do not wipe any part of the product using a wet cloth or any liquid.
- Only use the product as outlined in this User Guide.

## **Battery and Charging**

- Only use batteries, charging bases or chargers provided by Kogan.com.
- Do not dismantle, repair or modify the battery or charging base.
- Keep the charging base away from heat sources.
- Do not wipe or clean the charging base contacts using a wet cloth or wet hand. Please do not abandon used batteries arbitrarily. Used batteries should be disposed of by a professional recycling agency.
- If the power cable is damaged or broken, please stop using it immediately and contact Kogan.com for support.
- Ensure the vacuum is powered off during transportation. The product should be transported in original packaging where possible.
- If the machine is left unused for a long period, it should be fully charged and then placed in a cool and dry place. Charge the machine at least every 3 months so as to avoid damaging batteries due to excessive discharge.

## **Laser Safety Information**

- The laser distance sensor of the product does not produce dangerous laser radiation.

# COMPONENTS

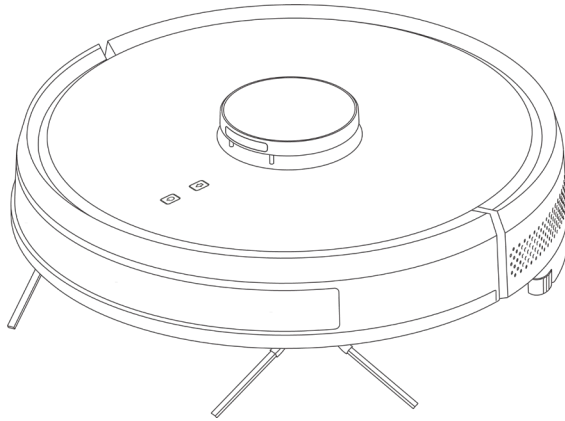

Kogan Smarterhome™ LX6 Robot Vacuum Cleaner (x1)

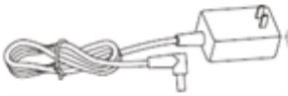

Power Adaptor (x1)

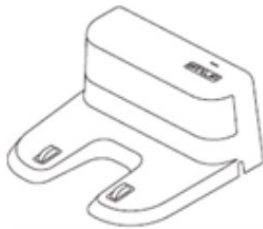

Charging Base (x1)



Dusting Brush (x1)



Left Side Brush (x2)  
Right Side Brush (x2)

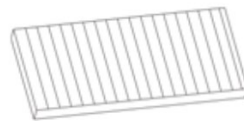

HEPA Filter Screen (x1)

# OVERVIEW

## Vacuum

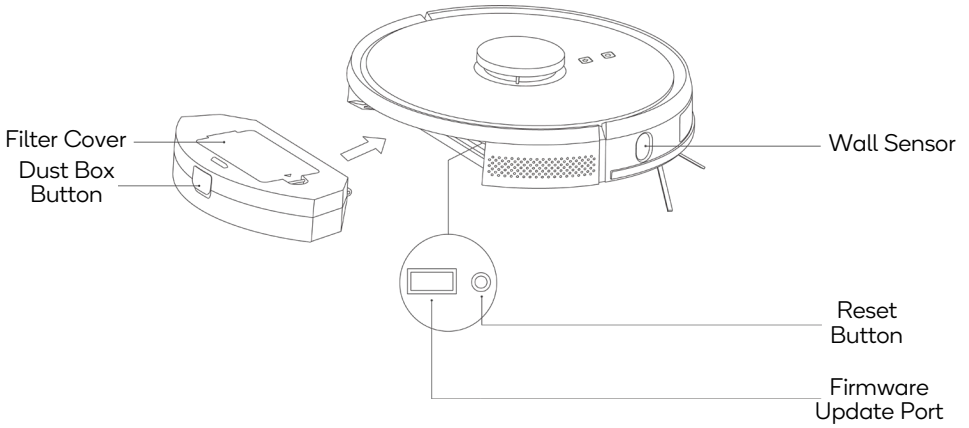

## Sensors and Body

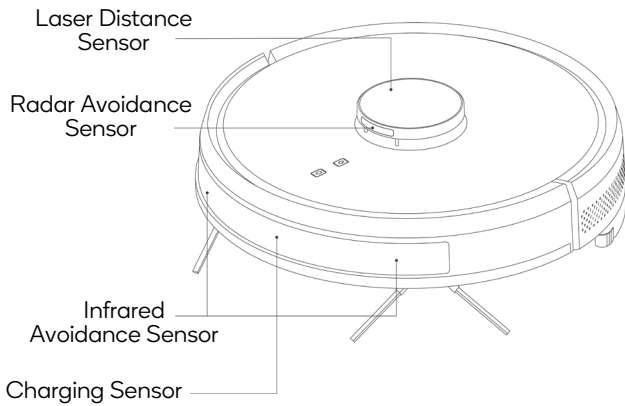

## Sensors and Body (cont'd)

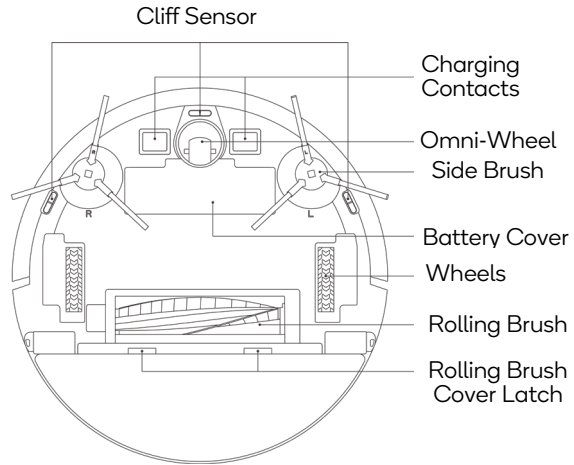

## Charging Base

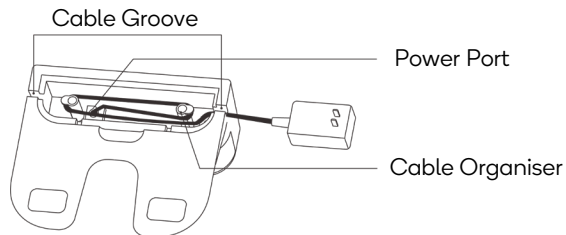
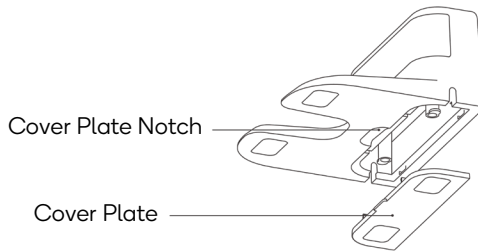
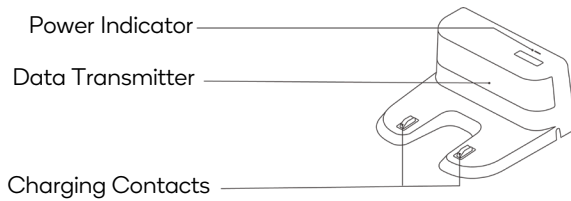

# BEFORE FIRST USE

Connect the power adapter and wrap any surplus cable onto the cable organising posts in the wiring duct.

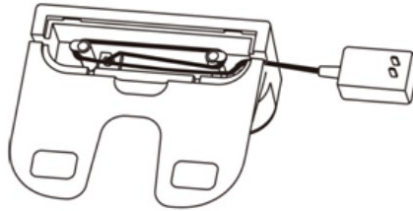

Place the charging base against the wall on a flat surface and connect the power.

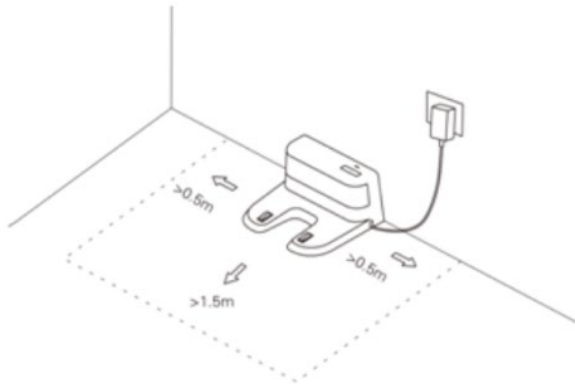

## Note:

- Ensure a space of at least 0.5m on both sides of the charging base and a space of at least 1.5m in front.
- If the power cord is in a spot that may interfere with the operation of the vacuum, it may be dragged by the vacuum, causing the charging base to lose power.
- The charging indicator is normally on when powered on and off when charged.

Avoid keeping the charging base in a location that will receive an excess of direct sunlight.

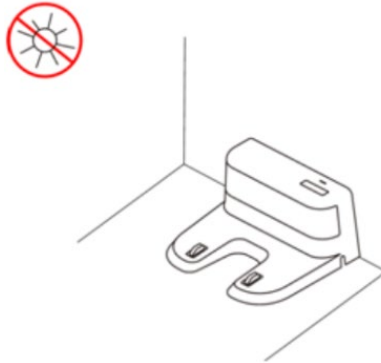

**Note:**

- If the charging base is relocated, the vacuum may lose its position and the map will be lost. When the vacuum is restarted, the vacuum will rebuild the map. The new map may lose data about out-of-limit areas.
- Direct sunlight will interfere with the recharging signal and consequently, the vacuum may be unable to return to the charging base.

**Installation of the Side Brush**

Match the left side brush 'L' and the right side brush 'R' with the 'L' and 'R' symbols on the bottom casing. Press both brushes into their corresponding positions until you hear a click.

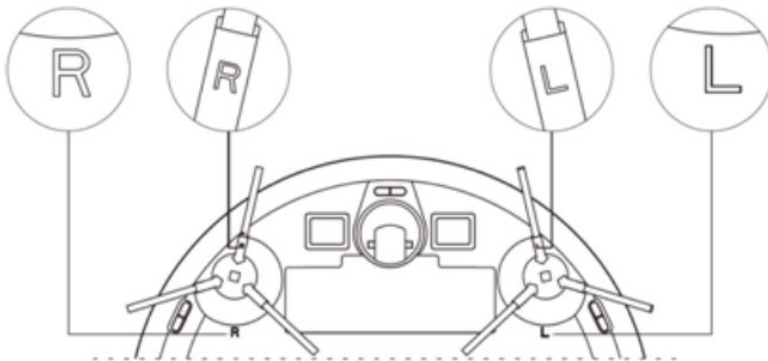

## Start-up and Charge

Press and hold the “Power” button to start the robot. Charge the vacuum on the charging base, and the indicator light will illuminate.

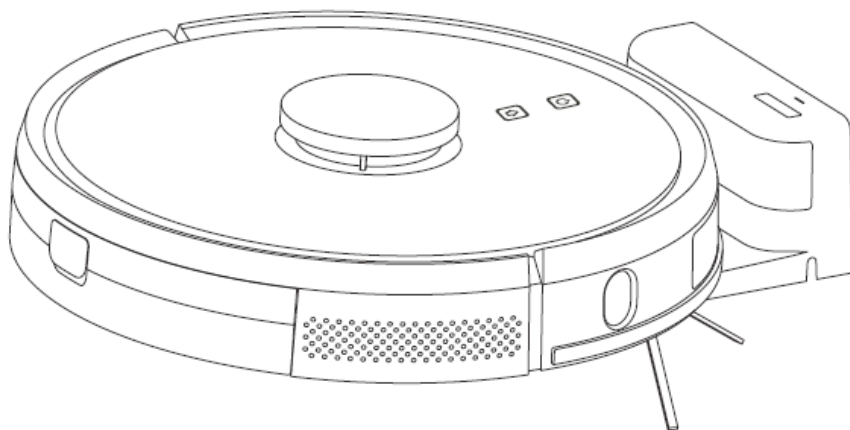

**Note:** If the device does not start due to low battery, manually move the robot and charge the vacuum on the charging base for some time. The robot will only work normally when the battery level reaches 30%.

## Cleaning

After the machine has charged, press the “Power” button on the vacuum, or use the mobile app. Press any button to pause when in use.

### **Note:**

- The robot cannot be used to remove liquids.
- If the battery level is less than 20%, the vacuum will not work. Please charge it.
- The machine will return to the charging base automatically if the battery level is less than 20% when in use. The robot will power on and start cleaning automatically after the battery level reaches 80%.
- Clear any cables, including the power cable, from the ground before use to avoid damage or injuries.

# CONNECT TO SMARTERHOME™ APP

## Install App

Download the “Kogan SmarterHome” app from the Play Store (Android) or App Store (iOS).

## Register

If you do not have a Kogan SmarterHome™ account, register or sign in with a verification code sent by SMS.

### To register:

1. Tap to enter registration page.
2. The system automatically recognises your country/area. You can also select your country code manually. Enter your email address and tap ‘Next.’
3. Alternatively, you can select ‘Register by mobile number’ and enter the verification code sent to you by SMS.
4. Create a profile on the next page to define your location and room.

10:54

< Email Mobile Number

### Register by Email

Australia +61 >

YourEmailAddress@gmail.com ✕

Get Verification Code

I Agree Service Agreement and Privacy Policy

10:55

< Email Mobile Number

### Register by Mobile Number

Australia +61 >

0412345678 ✕

Get Verification Code

I Agree Service Agreement and Privacy Policy

## Set device in pairing mode



When the device is first turned on, it may automatically enter pairing mode (the indicator light will be continuously flashing).

If not automatically in pairing mode when powered on, you can manually set the device in pairing mode by holding down both the Power and Home buttons simultaneously for 3 seconds, until the light begins flashing.



## Using AP Mode to add device

5. Once registered, tap “+” in the upper right corner of the app’s home page to add a new device through the network.
6. Select the product type from the list of options in the app (Cleaning Appliances > Vacuum Cleaners), and then select “**Other Mode**” from the top-right corner when asked to reset the device.

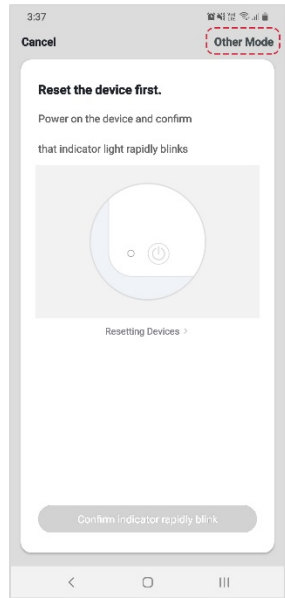
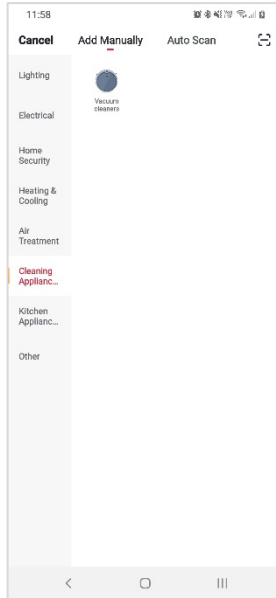
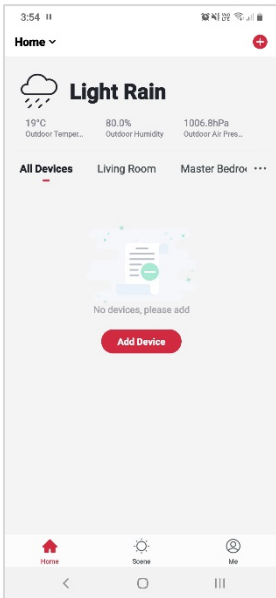

- 7. Select **“AP Mode”** for the set-up type.
- 8. Ensure that the device is in pairing mode, with the light flashing, and tap **“Confirm light is slowly flashing”**.
- 9. Enter your Wi-Fi details. It is important that your SmarterHome™ device and the app are connected to the same Wi-Fi network during setup.

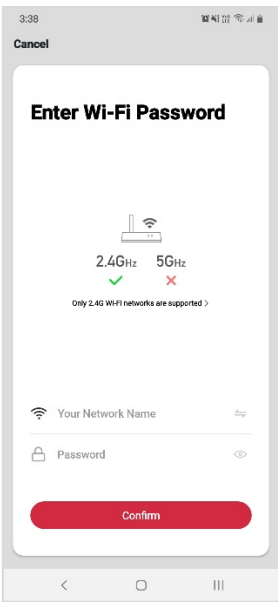
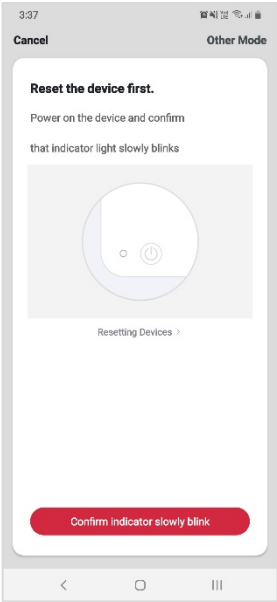
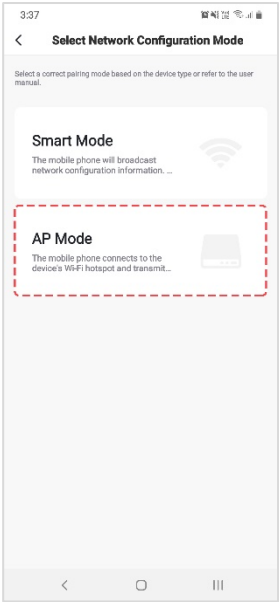

10. Follow the in-app prompts to continue AP Mode connection, which will pair your mobile phone to the device's Wi-Fi hotspot to ensure a connection.

### Note:

If the Wi-Fi hotspot does not appear on your phone in the list of available networks, your device may not be set in AP Pairing Mode correctly. Try repeating the steps outlined above to ensure your device is ready for connection.

11. The device will commence the pairing process and connect to the app. Ensure your Wi-Fi router, mobile phone, and the SmarterHome™ device are kept close until connection is complete.
12. After successfully being added, you will have the option to rename the device and assign it to a location. It will now be listed on the app's home page. Tap the device listing to enter its control page.

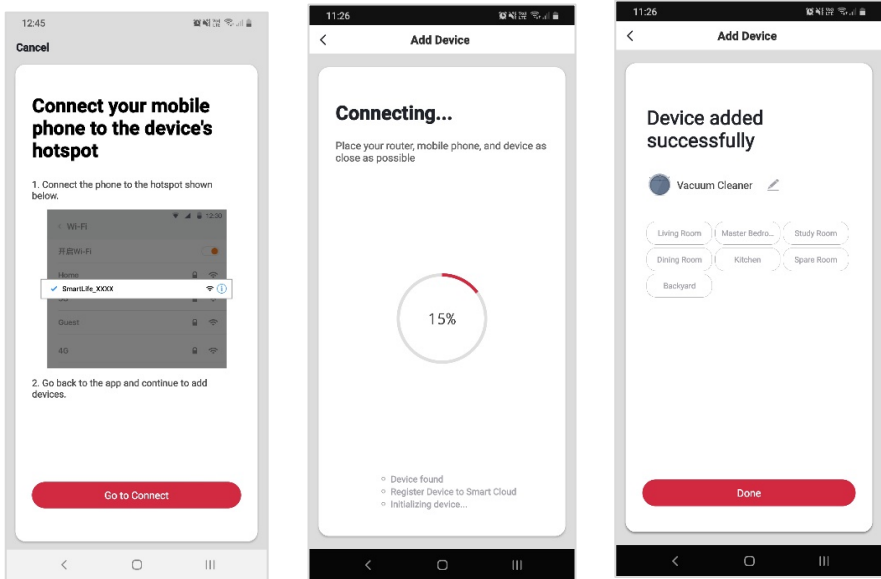

### Notes:

- The device and the app have to use the same Wi-Fi network.
- The device is only compatible with 2.4Ghz networks.

## Updating the firmware

When you enter the device interface page for the first time, you may receive a “New device firmware found” prompt. Select “Upgrade Now” and the device will download and install the latest firmware.

# OPERATION

## Button Functions

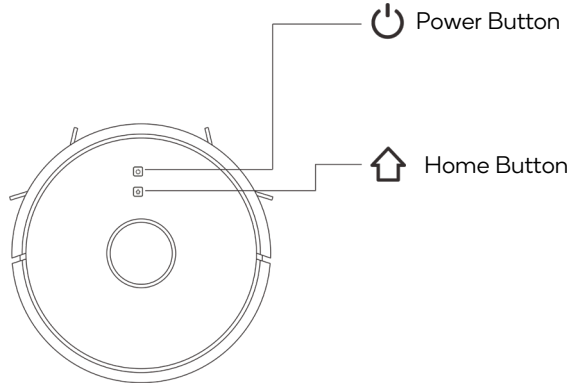

### Power Button

- Press to start vacuuming or pause.
- Press for 3 seconds to turn on or off.
- Press for 15 seconds for forced shutdown under abnormal circumstances.

### Home Button

- Press to charge or pause.
- Long press to start spot cleaning.

### Indicator light:

- Blue: Normal operation or charging.
- Red: Abnormal condition or low battery.
- Purple: Equipment is not connected to the network.

## Reset Wi-Fi:

- Press the “Power” and “Home” buttons simultaneously for 3 seconds.

## Turning ON/OFF

- Press “Power” button for 3 seconds, the indicator light will turn on and the machine will start.
- Press “Power” button for 3 seconds when the machine is in standby mode, the indicator light will turn off and the vacuum will shut down.

**Note:** The robot cannot shut down when it is being charged.

## Sweep/Pause:

- After the machine has started, press the “Power” button on the vacuum or start the machine using the mobile app, press any button to pause whilst in use.

## Charging

- Automatic mode: The vacuum will return to the charging base automatically after it is finished.
- Manual mode: Press the “Home” button to start charging. The indicator will illuminate and slowly flash.

**Note:** If the vacuum fails to locate the charging base, it will return to its original position automatically. Please put the vacuum back to the charging base manually.

## Fixed-Point Cleaning

- If a specific area requires deep cleaning, and you select a point on the map in the app, the robot will move near to the area automatically and sweep the floor in a 2m square. By default, it will clean the area twice, but the number of times can be set in the app.

## Cleaning Mode

- After the robot starts, it will scan and generate a map and divide it into areas automatically. The robot vacuum will vacuum areas one-by-one in an efficient pattern. The machine will return to the charging base automatically after it is finished, or if it is low in battery.



Do not move the machine during use. If the machine is moved, please put it back in the position it was in and it will attempt to reposition itself when it restarts. If it is relocated successfully, the vacuum will continue working according to the planned route. If it is not successfully relocated, the robot will rebuild the map, but may not be able to be charged without manual intervention.

## Spot Cleaning

As an alternative to using the app, you can manually move the robot to an area for spot cleaning. To activate spot cleaning press and hold the “Home” button for 3 seconds and the robot will vacuum the floor twice in a 1.5 x 1.5m area.



## Fixed-Time Cleaning

- You can set a fixed start time for the robot to commence cleaning from the app. The vacuum will automatically start cleaning at the set time and return to the charging base after it has completed cleaning.

## Wi-Fi Reset

- If you cannot connect your mobile phone to the robot after making changes in your router's configuration or network, press the "Power" and "Home" buttons simultaneously for 3 seconds. A voice prompt will confirm that "Wi-Fi has been reset" and the indicator light will slowly flicker purple.



## Do Not Disturb Mode

- The vacuum will not vacuum the floor or provide a voice prompt whilst it is in 'Do Not Disturb' mode. The amount of time the robot spends in 'Do Not Disturb' mode can be set during start-up or other times in the app.

## Cleaning Mode

- In the app, choose from; silent cleaning, automatic cleaning and strength cleaning modes. By default, the vacuum will be in automatic cleaning mode.

# CLEANING & CARE

## Roller Brush

Please ensure that the main roller brush is cleaned once a week.

1. Turn over the machine and press the latch on the roller brush cover to remove the roller brush.
2. Remove all dust outside and inside the roller brush using a small brush.
3. Reassemble the roller brush and press the cover firmly to fix it to the robot.

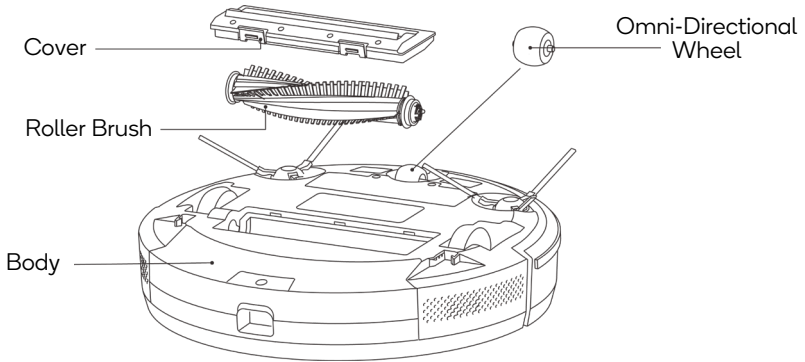

## Omni-directional Wheel

Please ensure that the omni-directional wheel is cleaned once a month.

1. Turn over the machine and pull the omni-directional wheel out upwards.
2. Remove dirt on the wheel and spindle.
3. Reassemble the wheel and press it back into position firmly.

## Side Brushes

Please ensure that the side brushes are cleaned once a month. For best results, replace the side brushes every 3-6 months.

1. Turn over the machine and pull the side brushes out upwards.
2. Remove any debris and reassemble the side brushes.
3. Ensure the left side brush (L) and the right side brush (R) correspond to "L" and "R" symbols on the bottom casing, press firmly to reinstall them.

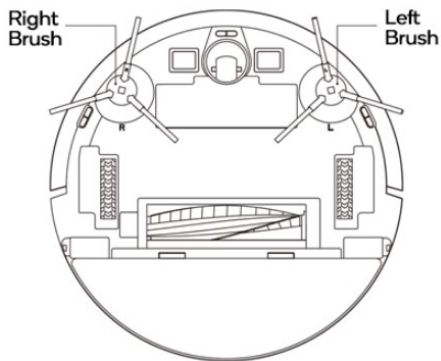

## Dust Box and Filter Screen

Please ensure that the dust box and filter screen are cleaned once a week.

1. Remove and empty the dust box.
2. Clean and dry the dust box.

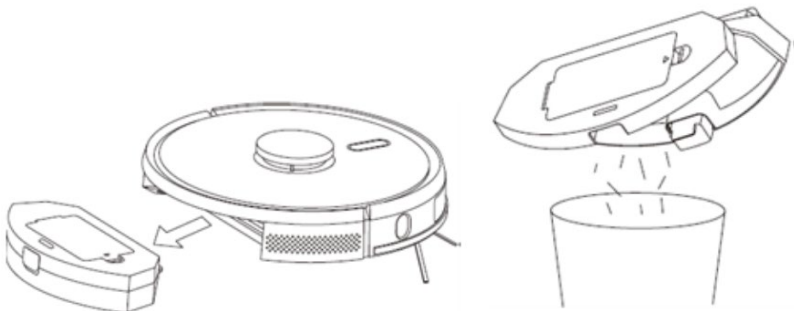

## Filter Screen

Please ensure that the filter screen is cleaned once a month.

1. Remove the filter gauze, filter sponge and HEPA filter screen.
2. Wash the filter gauze, filter sponge, HEPA filter screen and dust box using tap water.
3. Shake off any excess water and allow all parts to dry completely.
4. Install the dust box components in this order:
  1. Filter Gauze
  2. Filter Sponge
  3. HEPA Filter Screen

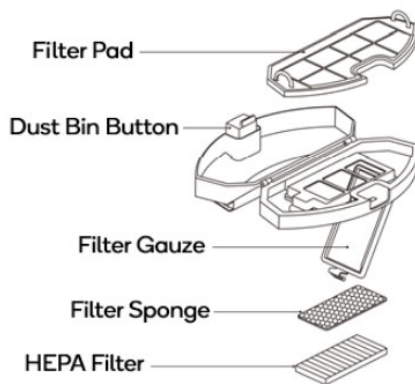

### Note:

- Only wash the filter screen using clean water and do not add any detergent.
- Do not clean the filter screen using a brush or your fingers.
- Dry the filter screen in the air for at least 24 hours.
- Replace the filter screen every 6-12 months.

## Sensors

Please ensure that the sensors are cleaned once a month.

Wipe the sensors on the machine using a soft dry cloth, including:

- The wall sensor located on the right side of the vacuum.
- The three cliff sensors at the bottom of the vacuum.
- The infrared avoidance sensor in front of the vacuum.
- The radar avoidance sensor on the top of the vacuum.
- The charging contacts. Please turn off the robot before cleaning the contacts.
- The data transmitter on the charging base.

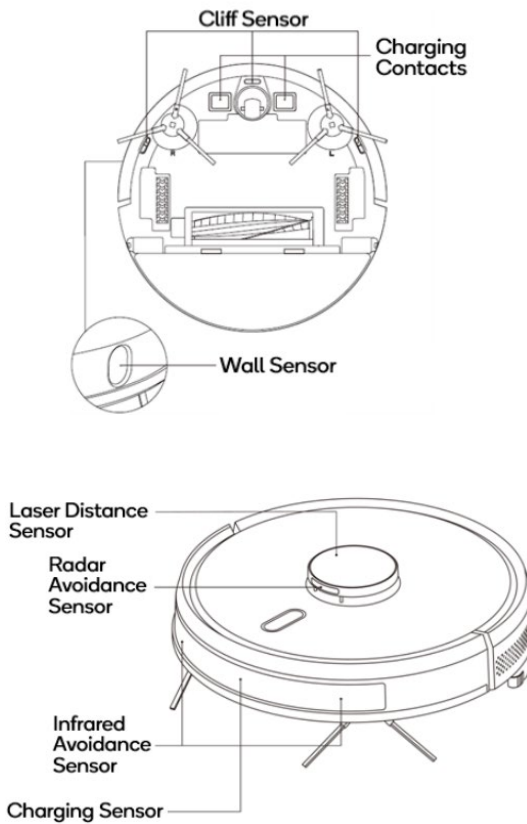

## **Battery**

- The vacuum features a high-performance lithium-ion battery. To maintain the battery's performance, please keep the vacuum charged and ready for daily use.
- If the robot is left unused for extended periods, please shut it down and keep it in a safe, dry environment. Charge it at least every 3 months to avoid damaging the batteries through excessive discharging.

## **Firmware Upgrade**

- The firmware can be upgraded when new firmware is available through the app. If the app detects new firmware, upgrade it according to the prompt. Always ensure that the battery level is at least 50% before a firmware upgrade. The robot should be placed on the charging base during the update.

## **System Reset**

- To perform a system reset, remove the dust bin, remove the rubber plug and press the reset button. Please be aware that the current map, Wi-Fi details, and settings will be lost.

# GOOGLE HOME CONTROL

## Note:

You will need to have set up a Google Home account prior to linking your Kogan SmarterHome™ device.

## Adding “SmarterHome” to the Google Home app

1. From the home page of the Google Home app, select the “+” icon to access the ‘Add and manage’ page.
2. Select ‘Set up device’, then under the Works with Google banner, select ‘Have something already set up?’
3. Select the search bar and type ‘Smarter Home’ to locate the Kogan SmarterHome™ service.

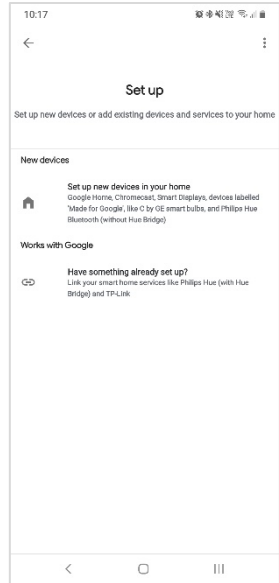
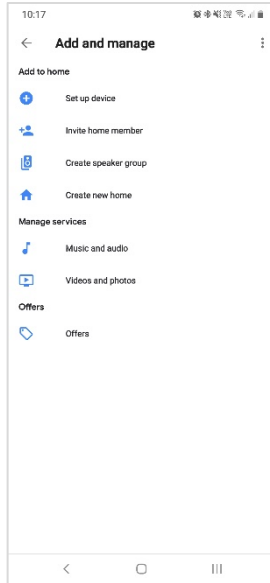
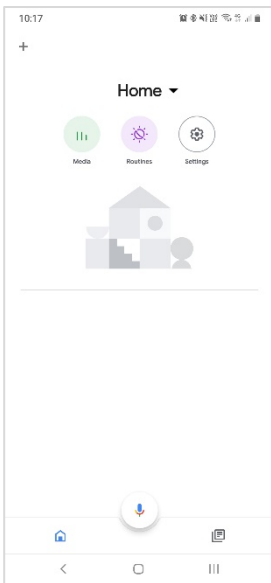

- 4. Tap 'Authorise' to grant Google permission to access the SmarterHome™ app and your devices.
- 5. From here, you will be prompted to sign into your SmarterHome™ account using either your email or mobile phone number, depending on which method you used to register your account.

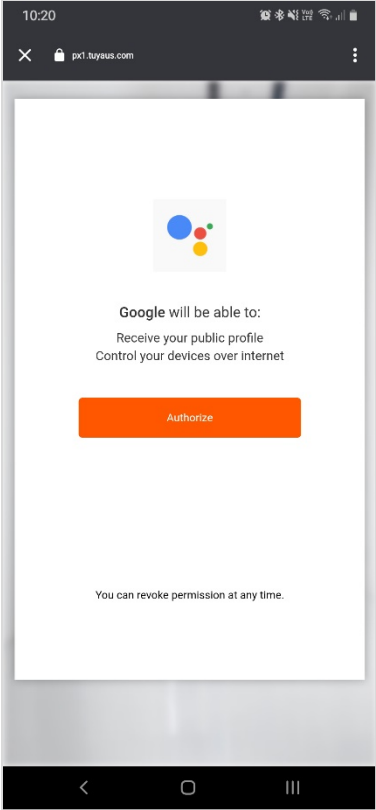
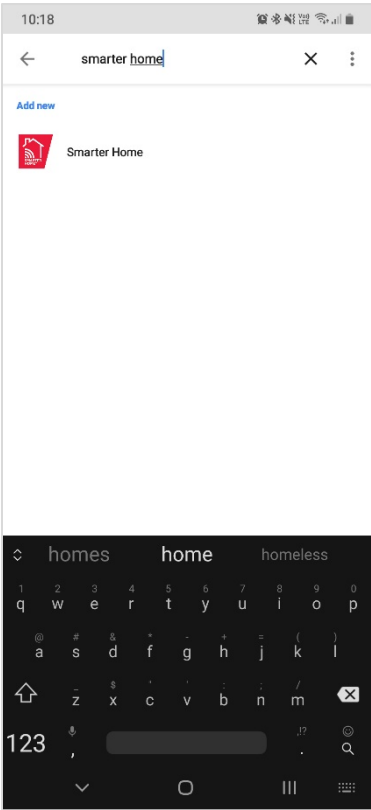

- Once connected, the app will display any compatible devices linked to your SmarterHome™ account. From here you can assign them to rooms and set up any routines.
- Tap on any of the devices to view a list of available commands.

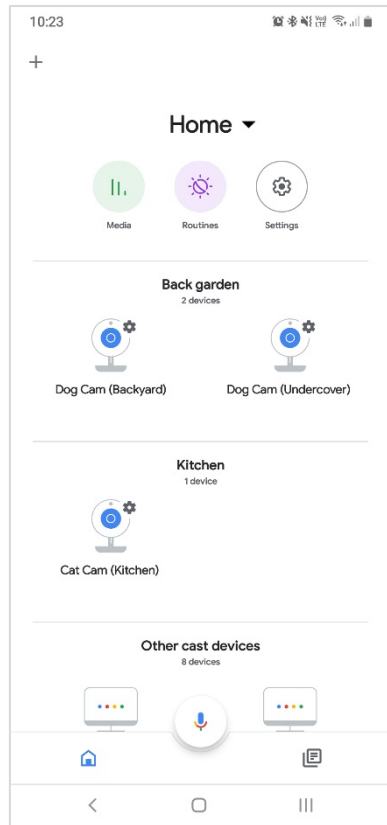
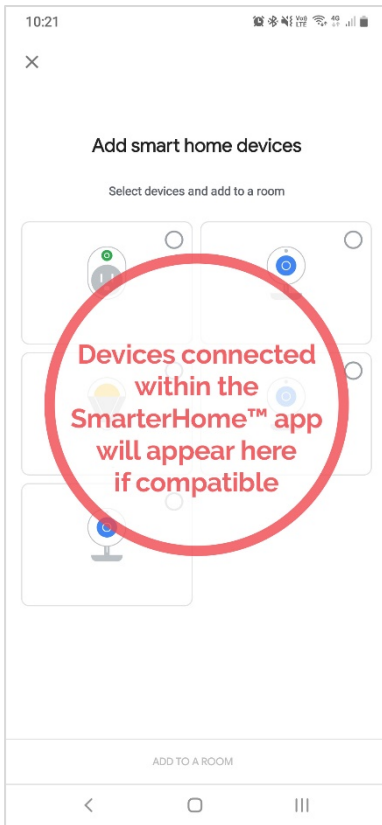

**Note:**

Please note that Google Home can only control the base/core functions of any compatible SmarterHome™ devices. To make full use of this product's smart functionality, please use the Kogan SmarterHome™ app.

# AMAZON ALEXA CONTROL

## Note:

You will need to have set up an Alexa account prior to linking your Kogan SmarterHome™ device.

## Adding “SmarterHome” to the Alexa app

1. From the home page of the Alexa app, select the “☰” icon in the top-right and select Skills & Games from the sidebar.
2. Select the search bar and type ‘Smarter Home’ to locate the Kogan SmarterHome™ skill.

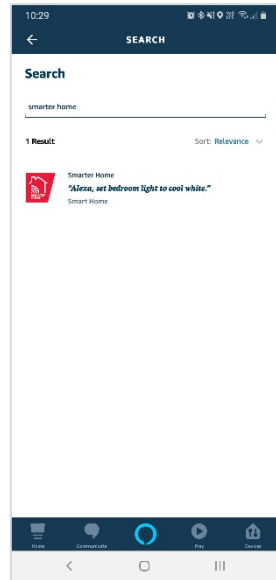
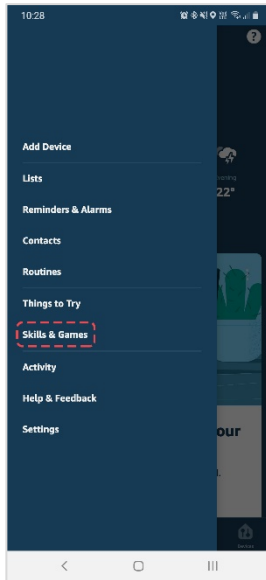
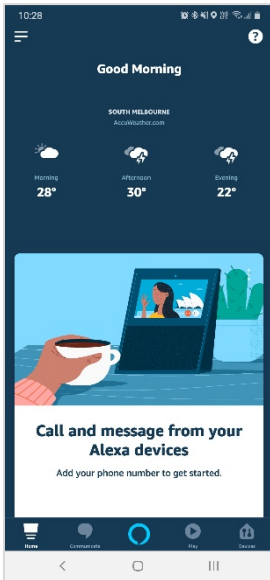

3. Tap 'Enable to Use' to add the Kogan SmarterHome™ skill to Alexa.
4. From here, you will be prompted to sign into your SmarterHome™ account using either your email or mobile phone number, depending on which method you used to register your account.
5. Tap 'Authorise' to grant Alexa permission to access the SmarterHome™ app and your devices.

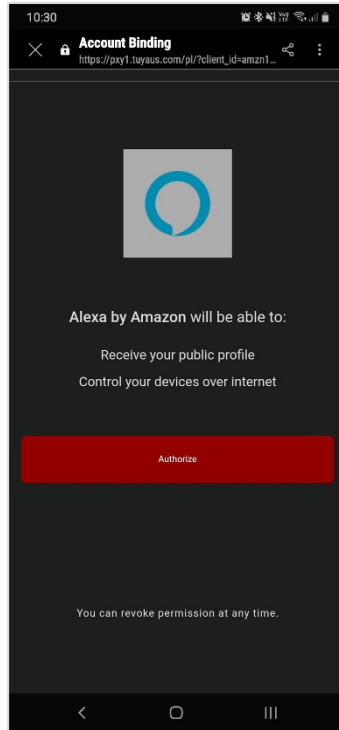
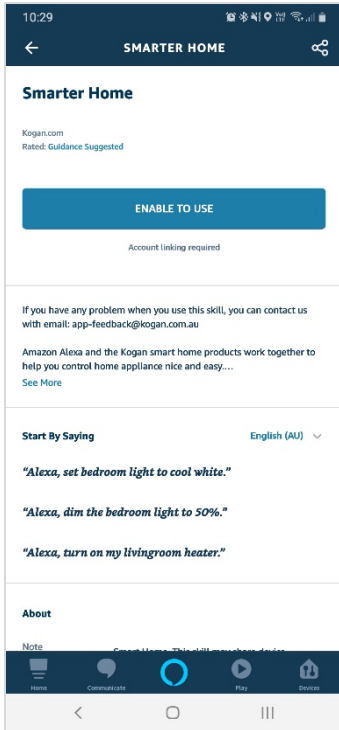

- Once connected, the app will perform a search and display the devices linked to your SmarterHome™ account.
- When your devices have successfully connected to the Alexa app, you will be able to control your Kogan SmarterHome™ devices via Alexa's voice commands.

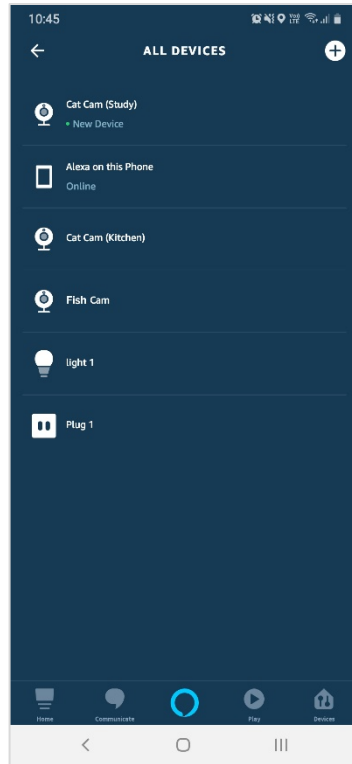
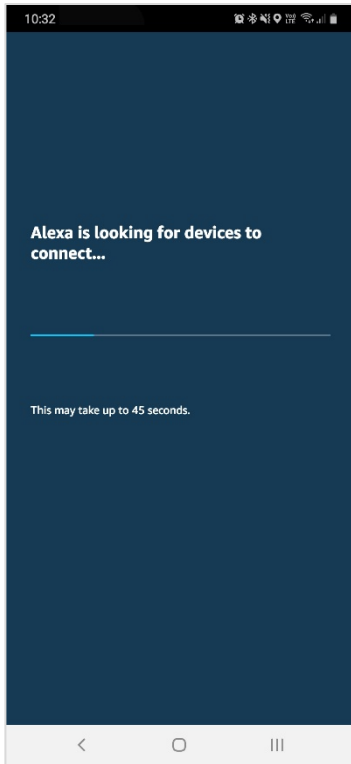

**Note:**

Please note that Alexa can only control the base/core functions of any compatible SmarterHome™ devices. To make full use of this product's smart functionality, please use the Kogan SmarterHome™ app.

# SPECIFICATIONS

## Vacuum

Overall dimension	350x350x100mm
Product weight	3.13kg
Battery	2600mAh lithium battery
Rated voltage	14.4V
Rated power	30W

## Charging Base

Overall dimension	160x143x80mm
Rated power	24W
Rated output	24W

# TROUBLESHOOTING

Problem	Solution
The robot will not turn on.	<ul style="list-style-type: none"> <li>• The vacuum may be very low in battery. If this is the case, manually place it on the charging pad, ensuring that the contacts lineup. Leave it to charge for longer than usual, as it will take some time to return from being very discharged.</li> <li>• If the temperature is lower than 0°C or higher than 40°C, please cease use until the temperature is between 0-40°C.</li> </ul>
The robot will not charge.	<ul style="list-style-type: none"> <li>• Check each end of the power adapter is connected to the wall and charging base securely. Move the machine from the base, and check whether the indicator light of the charging base is on.</li> <li>• If there is bad contact between the robot and the base, clean both the robots charging pads and the charging base's contact. Ensure the side brush is not interfering with charging.</li> </ul>
The vacuum will not return to the base.	<ul style="list-style-type: none"> <li>• The vacuum is too far away from the charging base; please put the vacuum on the charging base to reset.</li> <li>• The vacuum has been moved during its cleaning cycle.</li> </ul>
Abnormal behaviour.	Shut down and restart the machine.
Abnormal noise when in use.	The main brush, side brush or wheel may be entangled with foreign matters, please shut down the machine and remove debris.

<p>The robot has not been cleaning properly or dust is falling out of the device.</p>	<ul style="list-style-type: none"> <li>• The dust box is full, please clean it.</li> <li>• The filter screen is blocked, please clean or replace it.</li> <li>• The main brush is tangled, please clean it.</li> </ul>
<p>Wi-Fi will not connect.</p>	<ul style="list-style-type: none"> <li>• Wi-Fi signal is bad; please ensure that the robot is in an area with strong Wi-Fi.</li> <li>• Wi-Fi has not successfully connected, please reset the Wi-Fi, download the latest version of the app and try to reconnect it.</li> <li>• The password has been input incorrectly. Please remember Wi-Fi passwords are case sensitive.</li> <li>• The router outputs 5GHz, but the robot only works with 2.4GHz.</li> </ul>
<p>Fixed-time cleaning does not work.</p>	<p>A fixed-time clean will only commence if the robot's battery is above 30 percent.</p>
<p>The robot consumes a small amount of power when charged and on the charging base.</p>	<p>The vacuum consumes a little power if it is placed on the charging base by topping up the battery to preserve the life of the battery.</p>
<p>Does the battery need to be charged for 16 hours for the first three times?</p>	<p>The lithium battery can be used immediately after being charged and has no memory effect.</p>

Prompt tone	Solution
Error 1: Oh dear! I cannot find the dust collector	Cleaning stops when the dust box is taken out.
Error 2: Please check if the radar on top has been covered or blocked	The radar top is covered; the robot has not been placed in an open area. There should be no obstacles within an area of 6x6m <sup>2</sup> .
Error 3: Please place me in a new location and try again	Pick the machine up and move it.
Error 4: Please scrub the cliff sensor and restart me from a new location	The cliff sensor is covered or the vacuum is placed in an elevated location.
Error 5: Please scrub the front sensor and restart me from a new location	The infrared avoidance sensor is dirty or covered.
Error 6: Please scrub the right-hand sensor and restart me from a new location	The wall sensor is dirty or covered.
Error 7: Please scrub the radar housing on top and restart me from a new location	The radar avoidance sensor is dirty or covered.
Error 8: Please check if the bumper has been blocked in some way	The edge or collision sensor is stuck.
Error 9: Master, please clean the dust container and filter	The dust box is full or the filter screen needs to be replaced
Error 10: Dust container has been removed, please clean the container and filter	After error 9 is issued, when the dust chamber is removed, error 10 is triggered.
Error 11: I'm stuck, please help me!	The machine is stuck.



### **Need more information?**

We hope that this user guide has given you the assistance needed for a simple set-up. For the most up-to-date guide for your product, as well as any additional assistance you may require, head online to **[help.kogan.com](https://help.kogan.com)**

**kogan.com**