

EDWARDS & CO

Use + Care Guide

Olive

EC103



NZ AU



IMPORTANT

- Keep these instructions for future reference.
- Always follow the manufacturer's instructions.
- Read all instructions carefully before assembly and use of this stroller.
- Check that all items are present and undamaged.
- The correct use and maintenance of this product is essential.

Suitable for children from 6 months to 22kg

(Suitable from newborn to 22kg with the Newborn Insert Cushion accessory)

Independently safety tested for compliance with the Australian and New Zealand Standard AS/NZS 2088:2013

Welcome

Thank you for choosing Edwards & Co;
your family is now part of ours.

Edwards & Co started from humble beginnings in 2014 and has grown to include a team of people dedicated to bringing you the best for your baby. Our products are designed to impress, designed to last and designed to change. More importantly, they're designed for real-life families. No gimmicks, just good quality products with useful, easy to use features.

Olive is designed to grow with your family. If you plan on more than one child, Olive can easily adapt to accommodate two children. And don't worry, around 40% of pregnancies are happy surprises so even if it's not the plan, Olive will suit your needs either way!

To make sure you get the most out of Olive, please refer to this Use & Care Guide when using different parts of your stroller and accessories. For everything you need to upgrade Olive from a single to a double stroller, shop via our website or get in touch with our friendly team.

Because Olive will be your stroller for years to come, we hope to hear from you along the way, so feel free to contact us via any of the channels below if you'd like to get in touch.

We're so glad you came along for the ride.

**From the team
at Edwards & Co.**



Contents

Welcome	3
Warnings: Australia/New Zealand	6
General warnings and safety precautions	7
What's in the box	9
Olive stroller components	10
Using the Olive stroller	11
Attaching the front wheels	12
Attaching the rear wheels	12
Removing the front wheels	13
Removing the rear wheels	13
Attaching the seat unit	14
Removing the seat unit	15
Attaching the bumper bar	19
Removing the bumper bar	19
Unfolding the stroller	20
Folding the stroller	21
Reclining the seat unit	23
Attaching the Carry Cot	24
Removing the Carry Cot	24
Attaching the Avery Capsule	26
Removing the Avery Capsule	26
Using the Capsule Adapters	28
Attaching the Newborn Insert Cushion	30

Removing the Newborn Insert Cushion	32
Adjusting the footrest	33
Adjusting the handlebar	33
Using the harness buckle	34
Adjusting the shoulder strap height	35
Adjusting the harness straps	36
Using the parking brake	37
Using the front wheel swivel lock	38
Carrying the stroller	40
Attaching cover for lower connection points	41
Removing cover for lower connection points	41
Using the Olive Second Seat Kit	42
Using the upper adapters	43
How to care for and maintain your stroller	43
How to service your stroller	45
Inspect your stroller at least once a month	45
Service your stroller at least once every 6 months	45
WARRANTY	47

Australia/New Zealand



WARNING:

TO AVOID INJURY OR DEATH

ALWAYS APPLY THE BRAKES WHEN THE STROLLER IS STATIONARY.

- DO NOT LEAVE CHILDREN UNATTENDED.
- SECURE THE CHILD IN THE HARNESS AT ALL TIMES.
- DO NOT CARRY EXTRA CHILDREN OR BAGS ON THIS STROLLER.
- MAKE SURE CHILDREN ARE CLEAR OF ANY MOVING PARTS IF YOU ADJUST THIS STROLLER.

WARNING: USE THE HARNESS AT ALL TIMES.

WARNING: USE THE STRAP TO STOP THE STROLLER ROLLING AWAY.

WARNING: DO NOT USE THE SEAT WITH ANY OTHER MODELS OF STROLLER.

WARNING: DO NOT USE THE BASSINET ONCE THE CHILD CAN SIT UP UNAIDED.

General warnings and safety precautions



TO AVOID INJURY OR DEATH

Maximum weight limits

Child using this stroller in the main seat unit: **22kg**

Child using this stroller in the second seat unit (Double Kit required): **22kg**

Child using this stroller with the capsule attachment: **13kg**

Child using this stroller with the Carry Cot/bassinet attachment: **9kg**

Capacity of the storage basket: **10kg**

Capacity of the seat pocket: **1kg**

Minimum age limits

The seat is suitable for a child from 6 months.

Newborns must use the seat with the Newborn Insert Cushion accessory.

Releasing a child quickly in an emergency

Make sure the buckle is easy to access. It is important that your child can be released quickly in an emergency.

Keeping fingers away from moving parts

Take care of fingers and **NEVER** let a child fold or unfold the stroller. Fingers may jam in moving parts when folding or unfolding the stroller.

Do not use the stroller as a substitute baby cot or bed

The stroller is only designed to transport children safely. The stroller is not a baby cot or bed.

Using the harness safely

To avoid serious injury, always use the safety harness when your child is in the stroller. Always adjust the straps to fit firmly to your child's body size. A loose restraint or harness is **DANGEROUS**.

Never leave a harness connected when not fitted to a child in the stroller. The harness can form loops which may be a strangulation hazard.



Keeping the stroller stable

Do not place or attach weight on the handle or side of the stroller. Doing so may make the stroller's frame unstable. Use only approved Edwards & Co accessories.

Using the stroller on surfaces

Do not use this stroller on escalators, or on moving or mechanical conveyer belts. Always take your child out of the stroller when on stairs.

This stroller is designed for use on flat and gentle sloping surfaces. Take care on higher sloping or uneven surfaces. These surfaces increase the risk of the stroller tipping.

The brakes must be applied when the stroller is not moving.

Do not use the stroller on sand or near or in salt water

Store your stroller in a sheltered dry place and avoid beach use. Salt water or excessive moisture may cause corrosion on the fastenings and moving parts of this stroller. The manufacturer's warranty does not cover corrosion caused by environmental factors such as salt water or sand.

Never rinse the frame, wheels or housings with water. Water and/or debris can interfere with the internal mechanisms, including the brakes and damage your stroller.

Keeping the stroller away from fire and extreme heat

Do not store the stroller in areas where high temperatures may occur. Examples are a roof space, or beside shed walls that can get hot.

Approved accessories

Only use accessories approved by Edwards & Co.

Only use a mattress (in the Carry Cot) supplied by Edwards & Co.

What's in the box

Note: Check that all items are present and undamaged.

Use + Care Guide
(this instruction
manual)

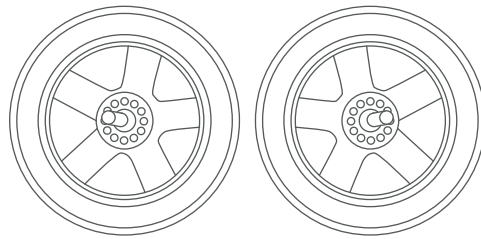

2 x Rear Wheels

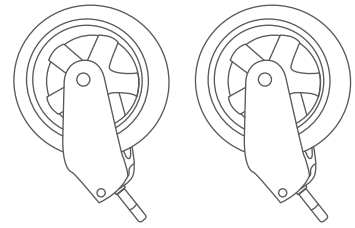

2 x Front Wheels

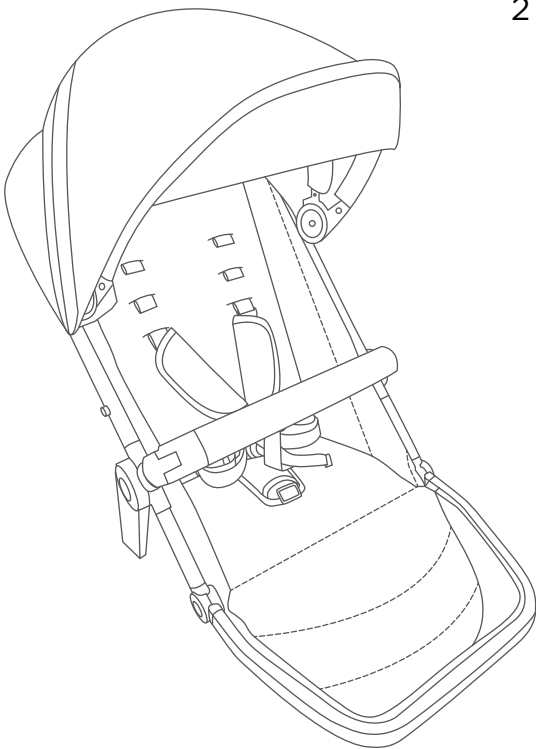

1 x Seat Unit & Canopy & Bumper Bar



2 x Canopy Screws
(For additional fixing
of the canopy, please
use the 2x screws
provided to screw
through the fabric tab
into the seat frame)

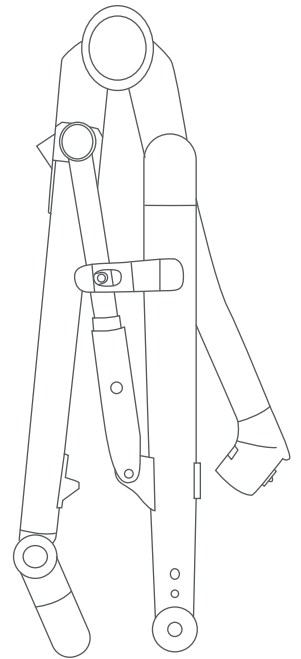

1 x Stroller Frame



1 x Cover for Lower Connection Points

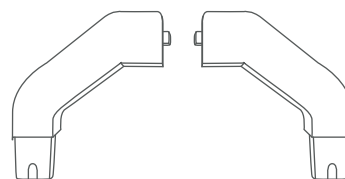

1 x set of Upper Adapters
(for use in Stroller's Upper
Connection Points)

Olive stroller components

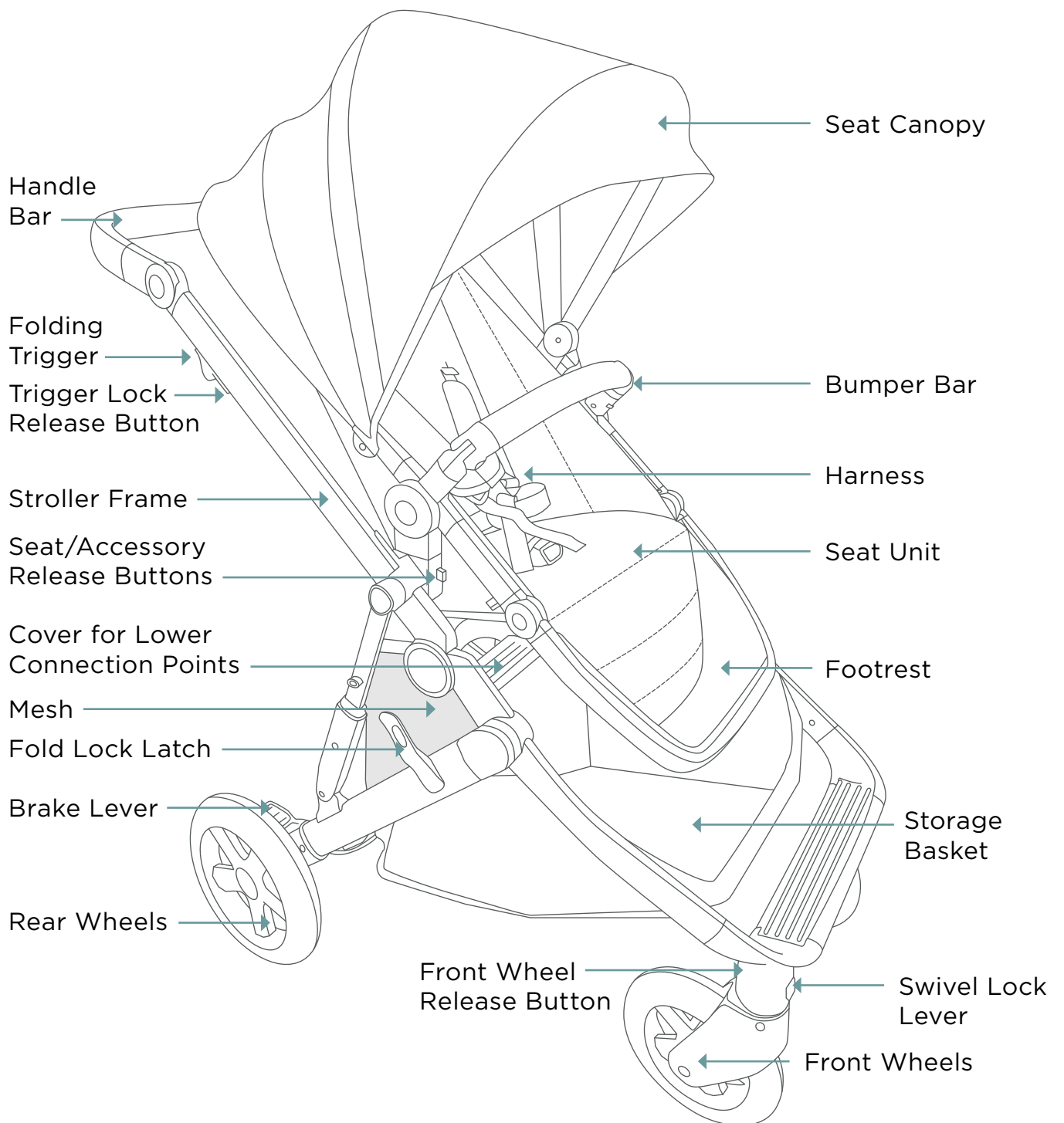

Using the Olive Stroller

Attaching the front wheels

1. Locate the metal pin on the front wheel. Insert this into the front wheel housing on the stroller frame.

2. Once installed, pull the wheel to confirm a secure connection.

 You will hear a click when the wheel connects correctly.

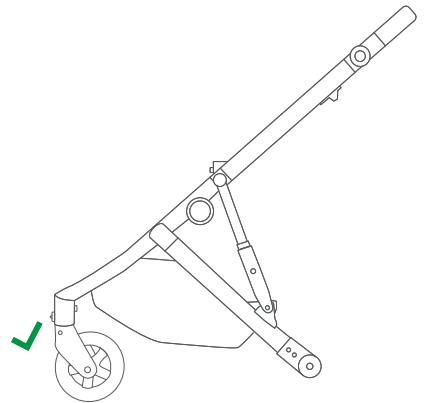
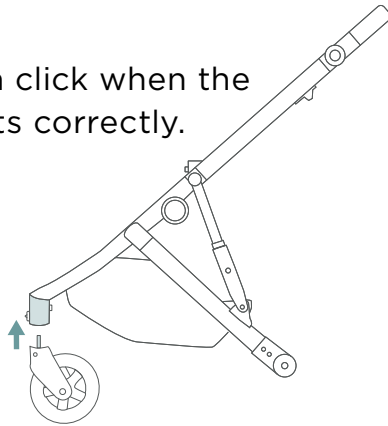
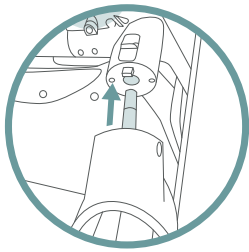

Attaching the rear wheels

1. Locate the metal pin on the rear wheel.

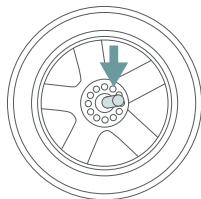

2. Press the wheel release button in the centre of the outer side of the wheel. At the same time, insert the metal pin into the rear wheel housing on the stroller axle.

 You will hear a click when the wheel connects correctly.

3. Once installed, pull the wheel to confirm a secure connection.

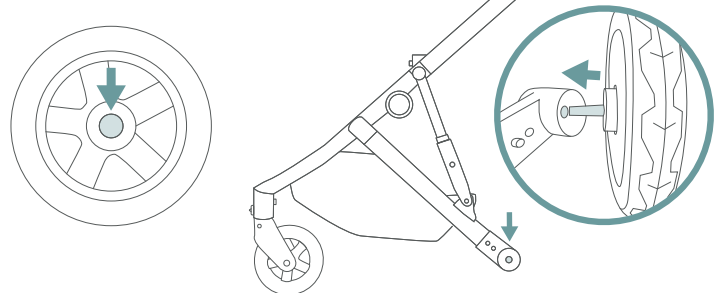
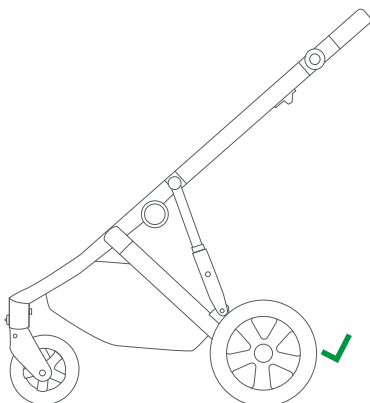

Removing the front wheels

- 1.** Press the wheel release button on the back of the front wheel housing.

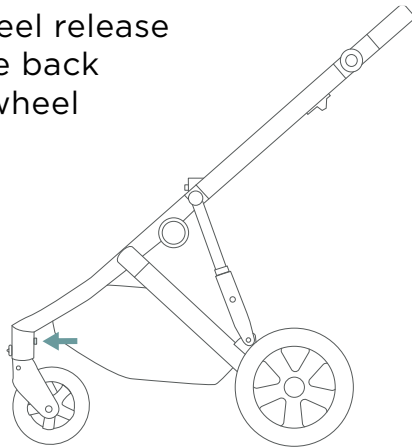
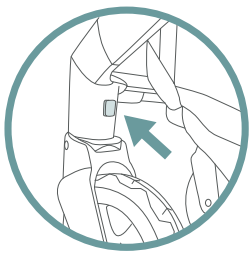

- 2.** Pull the wheel downwards.

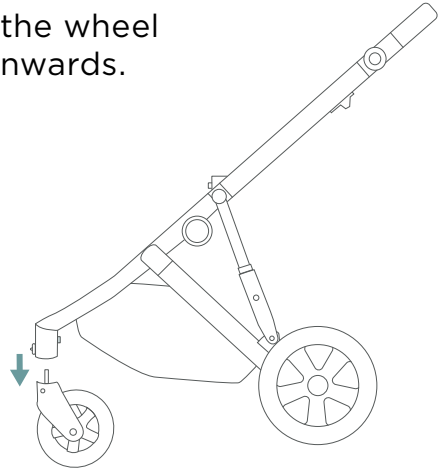

Removing the rear wheels

- 1.** Press the wheel release button in the centre of the rear wheel.

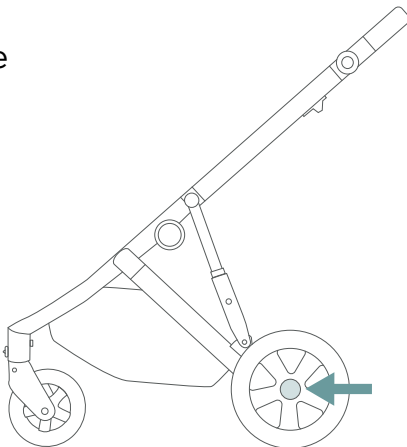

- 2.** Pull the wheel outwards.

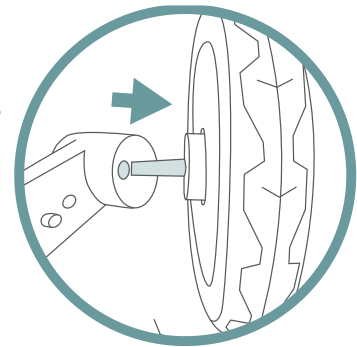

Attaching the seat unit

1. Insert the connectors on the seat unit into the connection points on the stroller's frame.

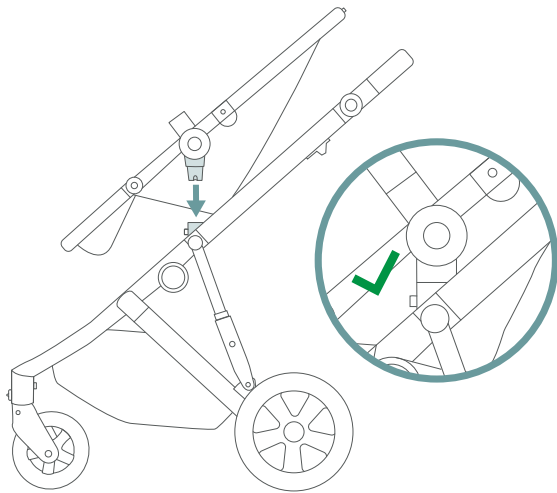

2. Attach the seat in the forward position or in the reverse position (with baby looking at you). Pull the seat unit upwards to check it is secure.

✔ You will hear a click when the seat unit connects correctly.

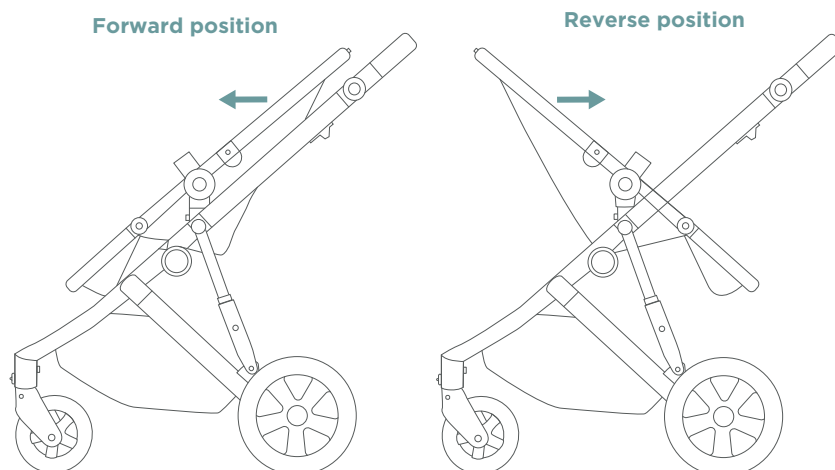

Removing the seat unit

1. Locate the two seat release buttons on either side of the stroller's frame, just below the seat unit connection points.

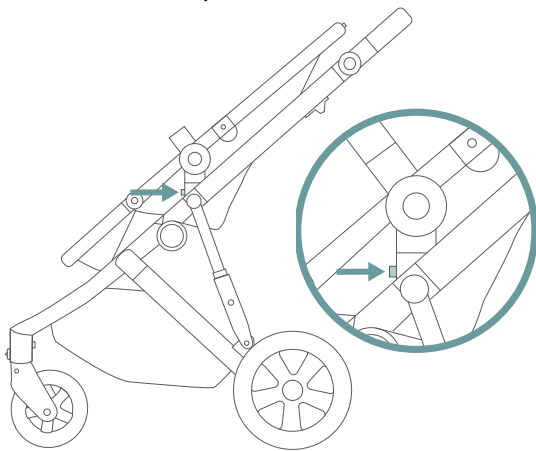

2. Push in one seat release button until it stays in place.

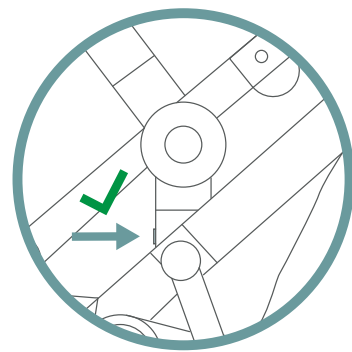

3. Push in the seat release button on the other side until it stays in place.

Note: The buttons do not need to be pressed simultaneously.

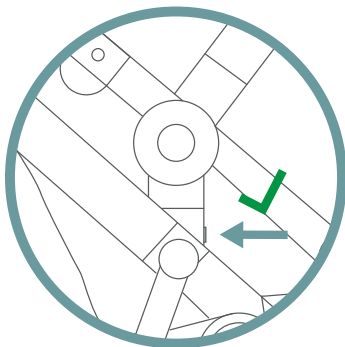

4. Lift the seat straight up.

Note: Do not lift the seat on an angle.

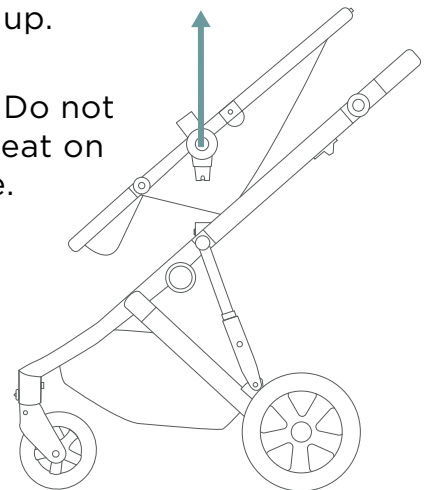



Attaching the bumper bar

1. Locate the metal pins on either end of the bumper bar.

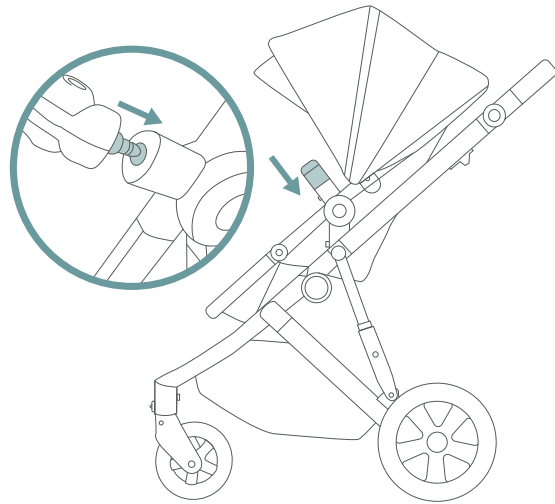

2. Insert the metal pins into the connection points on either side of the seat unit until they click into place. Pull the bumper bar to ensure it is securely connected.



-  You will hear a click when the pins connect securely within the housing.

Removing the bumper bar

1. Locate the black release buttons below the bumper bar's two connection points.
2. Press and hold one button while pulling the end of the bumper bar out. Repeat at the other end.

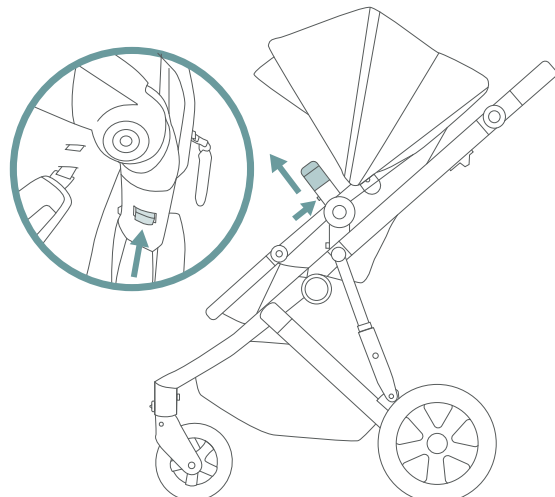

Unfolding the stroller

WARNING: To avoid damage to the handlebar lining, take care when placing the handlebar on the ground.

1. Stand the folded stroller upright.

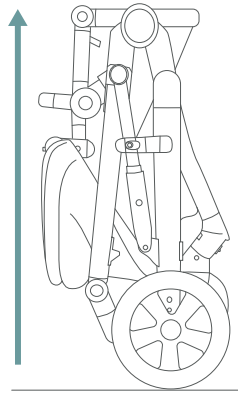

2. Locate the fold lock latch on the right side of the stroller frame. Lift this away from the catch.

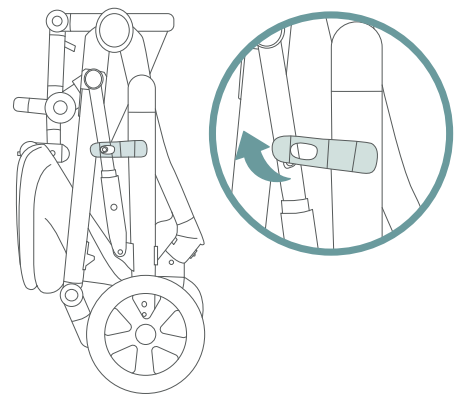

3. Slowly pull the stroller's handle upwards until the central fold joint locks into place.

✓ You will feel the stroller click into place.

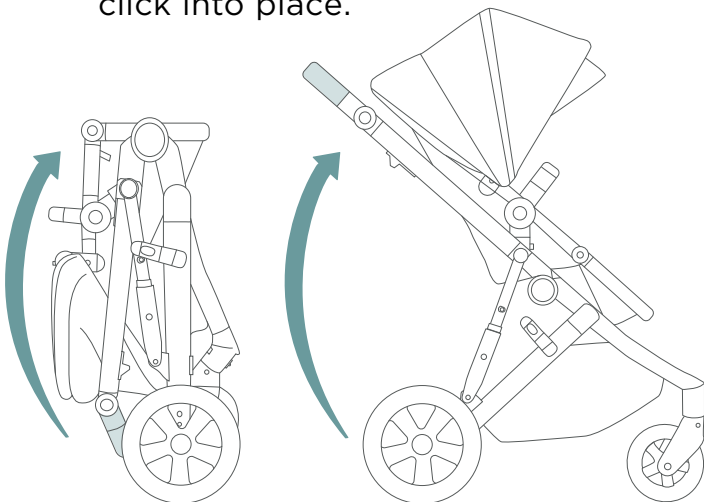

Folding the stroller

WARNING: To avoid damage to the handlebar lining, take care when placing the handlebar on the ground.

Be careful of moving parts when folding the stroller.

Note: To fold the stroller, ensure the seat is in the forward facing position (with baby looking away from you), or has been removed from the stroller frame. The stroller cannot be folded with the seat unit in the reverse position.

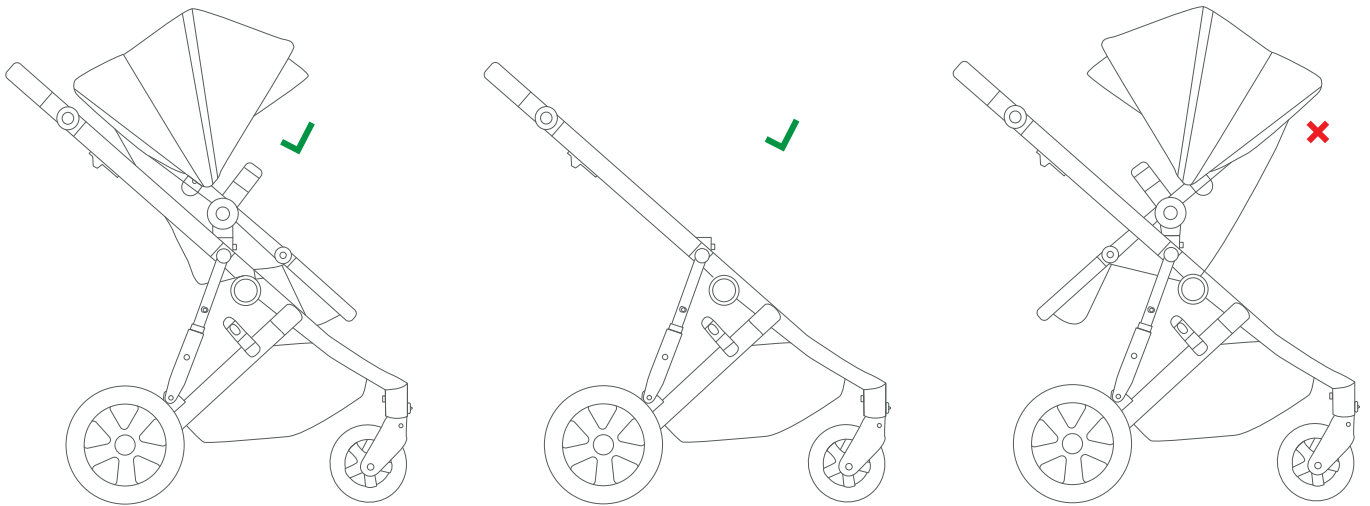

1. Engage the brake by pushing down the red brake pedal. Ensure the brake has locked both rear wheels. Push the stroller a little to make sure the brake is engaged and working.

2. Locate the two fold triggers - one on each side of the stroller frame. Locate the small black button under the trigger on the right side.

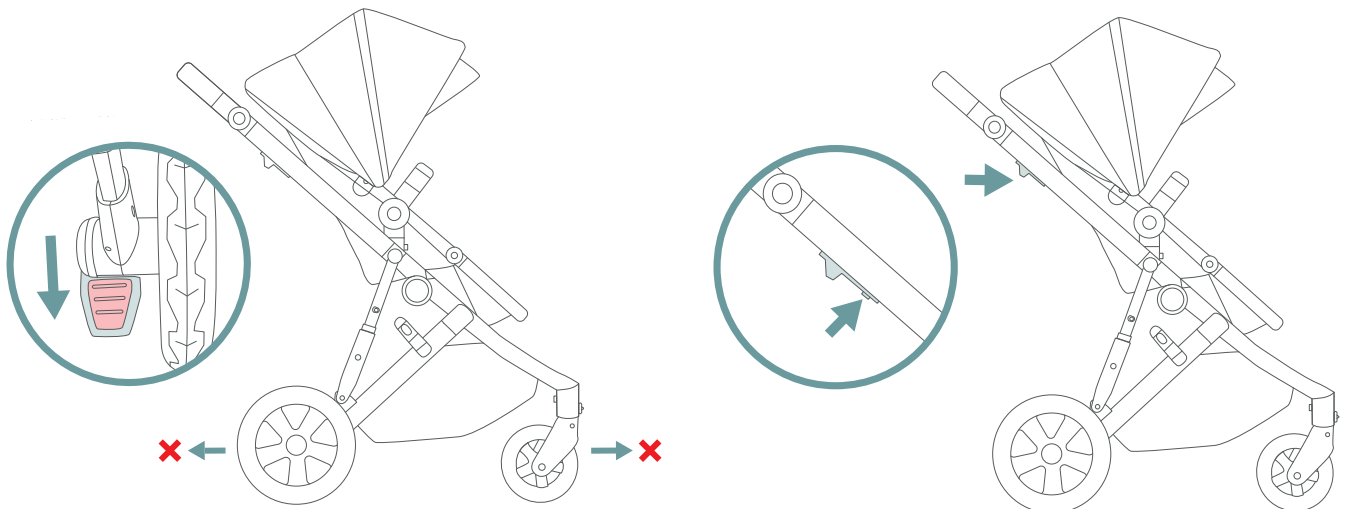

- 3. Press and hold the black button, while sliding both fold triggers up the frame towards you.

Note - right trigger: The small black button locks the right fold trigger. It is necessary to press this to enable the trigger to slide.

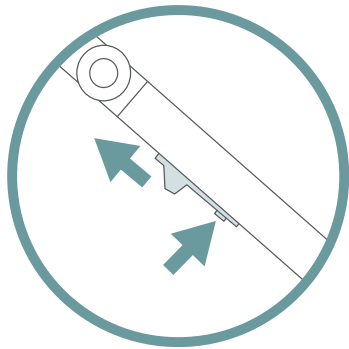

- 4. Push the handlebar towards the floor until the fold lock latch on the right side of the stroller's frame locks into place.

✓ When the fold lock latch is in place, the stroller will not unfold when you carry it.

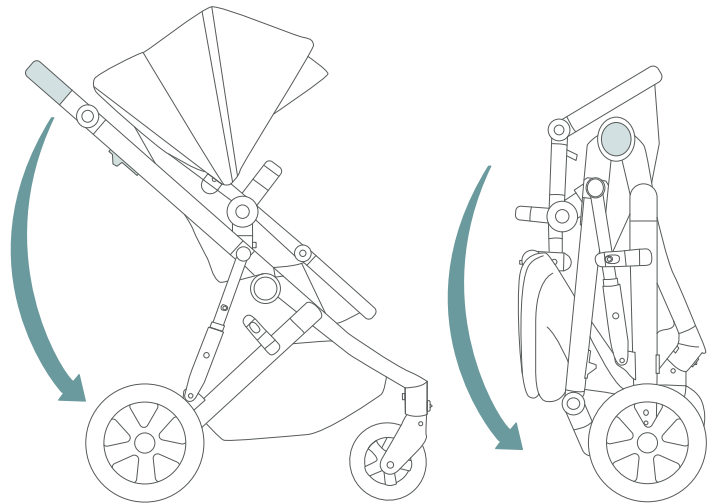

Note - For a more compact fold with the seat unit in place, position the footrest at a right angle.

Locate the two buttons on the outer sides of the footrest hinge. Press buttons simultaneously to adjust the footrest angle.

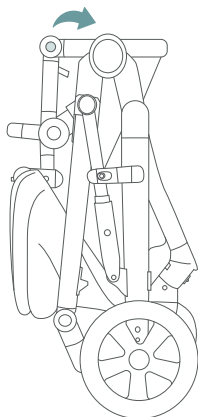

Carrying the stroller - We recommend lifting the stroller by grabbing the area near the fold hinge.

Always make sure the fold lock latch is secured before lifting or carrying the stroller.

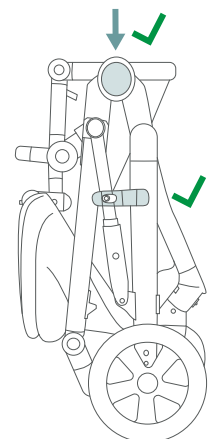

Note - If the fold lock latch does not engage, check the front wheels have not jammed. When folding, the front wheels should rotate away from the stroller for a proper fit. To correct it, unfold the stroller and fold again ensuring the wheels rotate as described.

Reclining the seat unit

1. Locate the circular buttons at the connection points on each side of the seat unit.

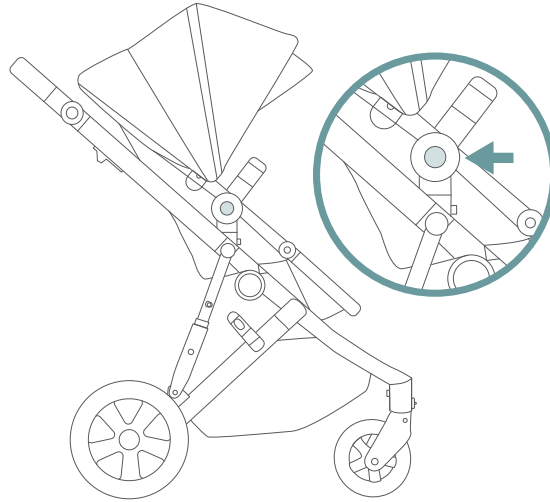

2. Press both of these buttons in simultaneously to raise or lower the seat to the desired position. The seat can be set at one of three heights: Upright, Reclined, and Horizontal.

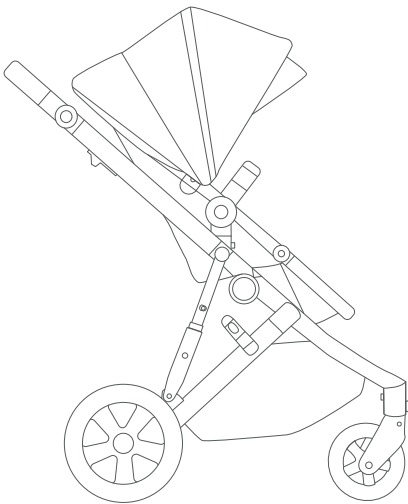

Upright
6 months +

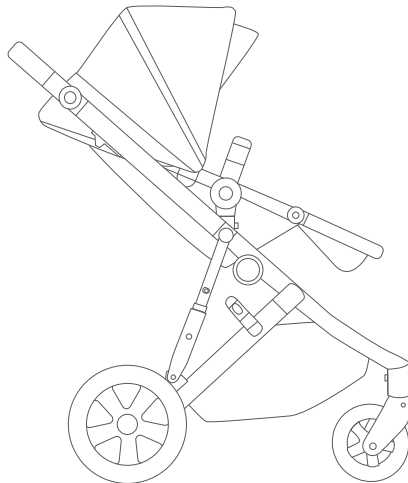

Reclined
6 months +
(sleeping position)

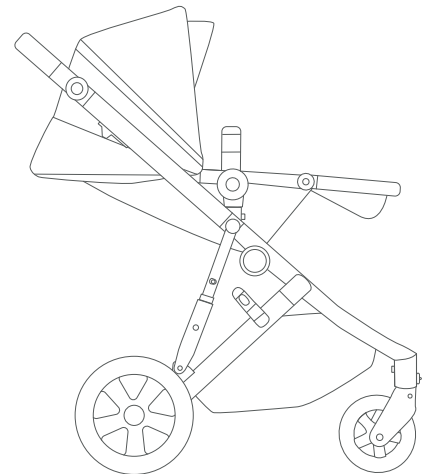

Horizontal
WARNING -
newborn:

when using the seat in this position for a newborn, the Newborn Insert Cushion must be used. See “Using the Newborn Insert Cushion”.

Attaching the Carry Cot

(sold separately)

1. Insert the Carry Cot's connectors into the connection points on the stroller frame. Pull the Carry Cot upwards to check it is secure.

✓ You will hear a click when the Carry Cot connects correctly.

Recommendation:

Install the Carry Cot in the reverse position (with your baby looking at you).

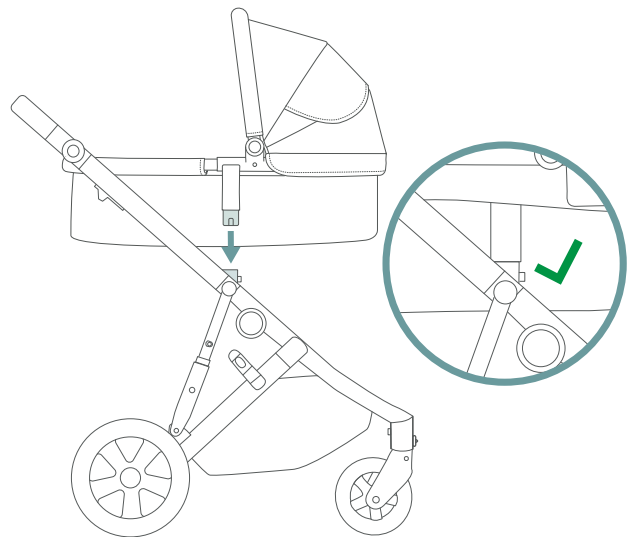

Removing the Carry Cot

1. Locate the two Carry Cot release buttons on the stroller frame, just below the Carry Cot's connection points.

2. Push in one release button until it stays in place.

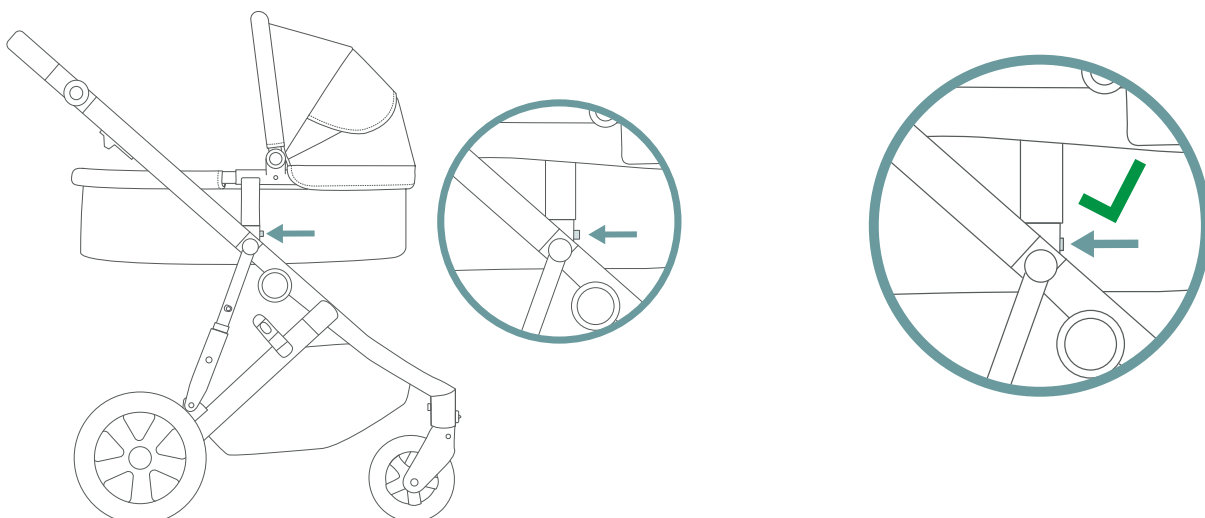

3. Push in the release button on the other side until it stays in place.

Note: The buttons do not need to be pressed simultaneously.

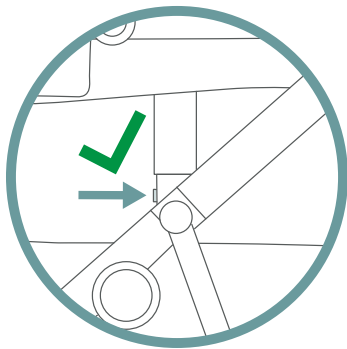

4. Lift the Carry Cot straight up.

Note: Do not lift the Carry Cot on an angle.

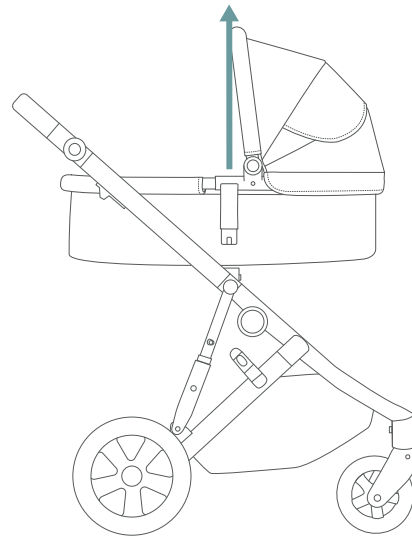

Attaching the Avery Capsule (sold separately)

Recommendation: Attach the Avery Capsule in the reverse position (with your baby looking at you).

1. Insert the Avery Capsule's connectors into the connection points on the stroller frame. Pull the Avery Capsule upwards to check it is secure.

✓ You will hear a click when the Avery Capsule connects correctly.

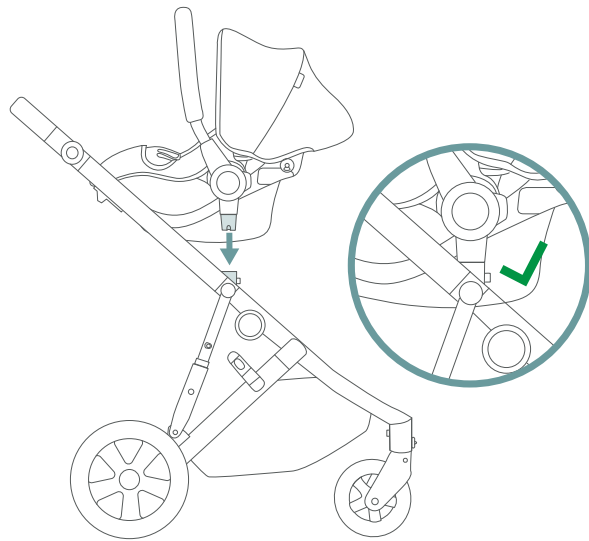

Removing the Avery Capsule

1. Locate the two capsule release buttons on the stroller frame, just below the capsule's connection points.

2. Push in one release button until it stays in place.

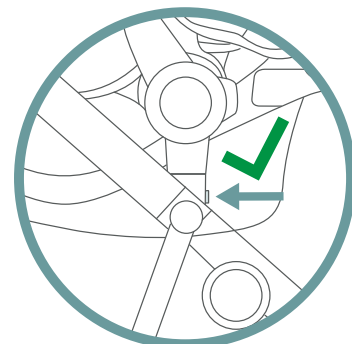
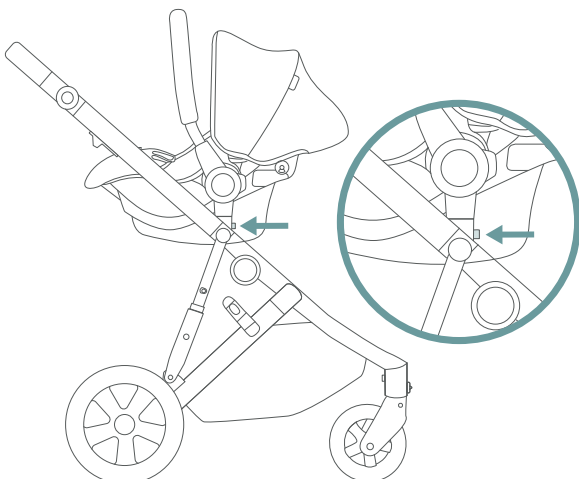

3. Push in the release button on the other side until it stays in place.

Note: The buttons do not need to be pressed simultaneously.

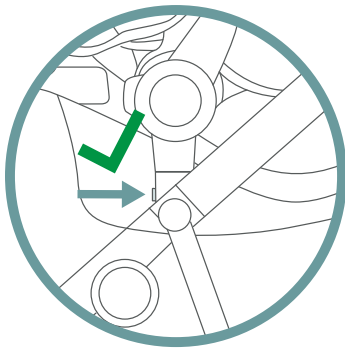

4. Lift the capsule straight up.

Note: Do not lift the capsule on an angle.

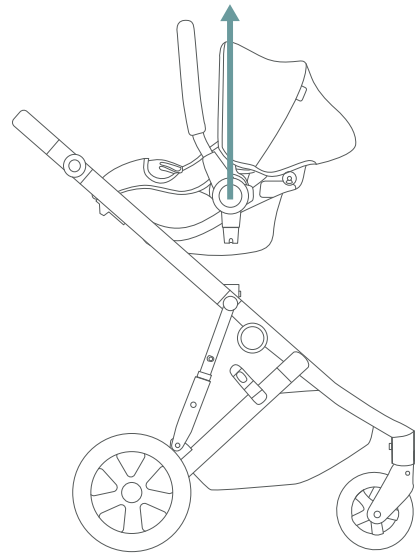

Using the Capsule Adapters

(sold separately)

Note: The stroller can be folded with the Capsule Adapters connected.

The Capsule Adapters are required when using another brand's capsule with the Olive stroller. These adapters are not required when using the Avery Capsule. Please see your Capsule Adapter instruction manual to confirm the capsule models that are approved for use with your Olive stroller.

Installing the Capsule Adapters

1. Insert the Capsule Adapters into the connection points on the stroller frame. (L = Left; R = Right)
2. Pull each adapter upwards to check they are both secure.

 You will hear a click when the adapters connect and lock correctly.

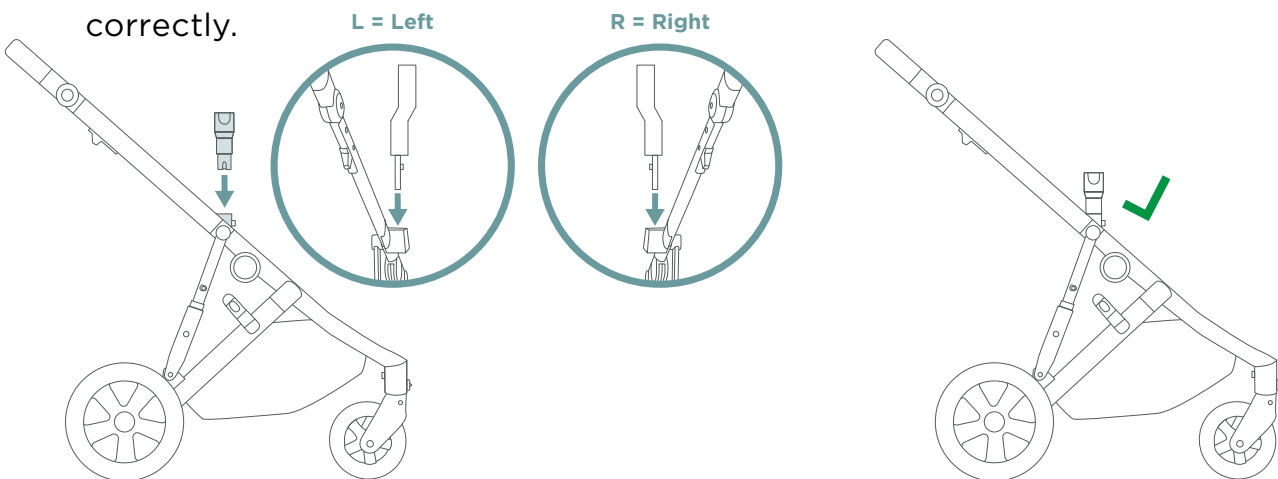

Removing the Capsule Adapters

1. Locate the adapter release buttons on the stroller frame, just below the adapters' connection points.

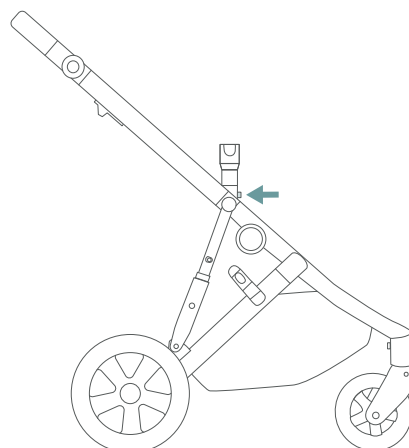

- 2.** Press the release buttons.

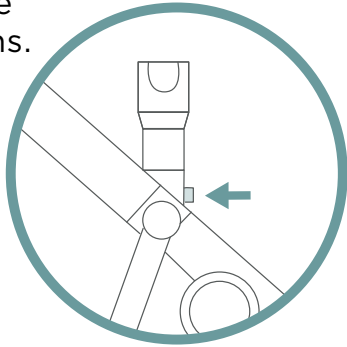

- 3.** Lift the adapters out of the stroller frame.

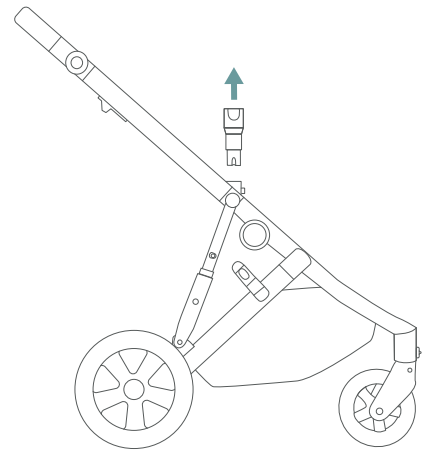

Removing the capsule from the stroller

1. Locate the capsule release mechanism on your capsule. (For more information, please read your capsule's instruction manual.)
2. Engage the capsule release mechanism and lift the capsule straight up. Do not lift the capsule on an angle.

Attaching the Newborn Insert Cushion (sold separately)

WARNING: This cushion is not a substitute for a bassinet or a bed. Never leave a baby asleep in the stroller unattended.

The Newborn Insert Cushion converts the seat unit into a surface approved for use with newborn babies.

The Newborn Insert Cushion is designed to be used with the seat unit in the horizontal position.

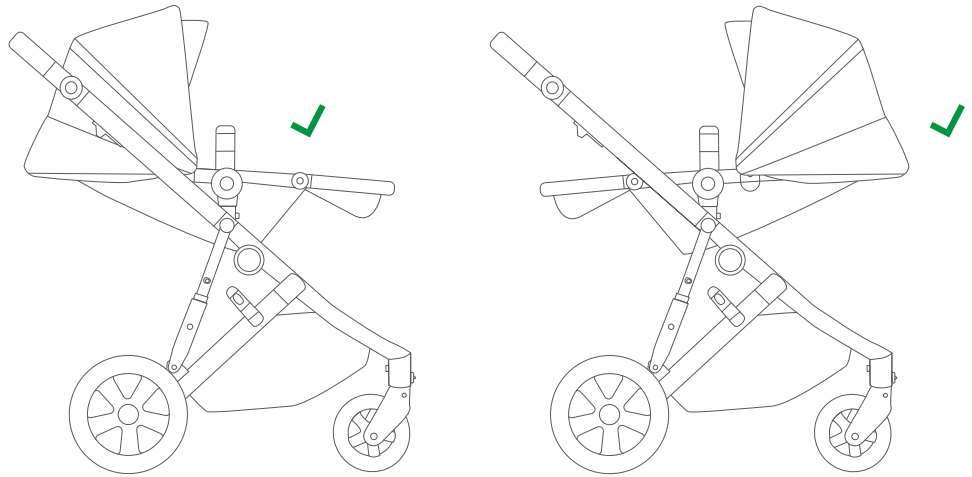

1. Remove the seat unit's shoulder pads and crotch pad.

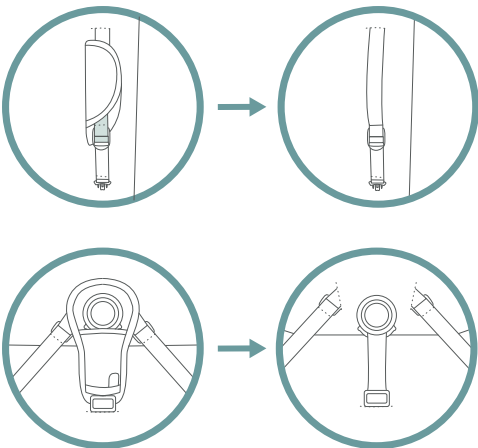

2. Check the lumbar wedge is in position in the back of the Newborn Insert Cushion.

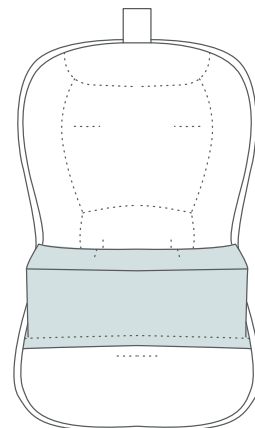

3. Ensure the shoulder strap height is at the lowest position.

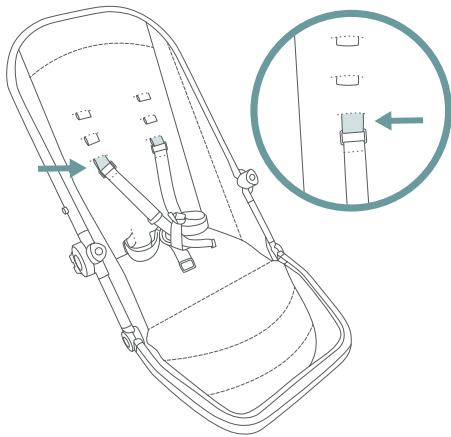

4. Thread the shoulder, hip and crotch straps through the liner.

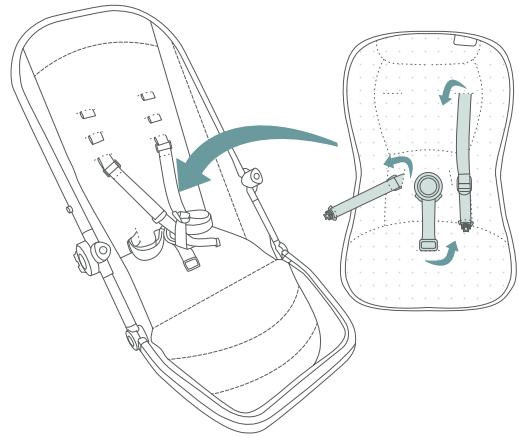

5. Guide the shoulder straps through the loops at the back of the head hugger.

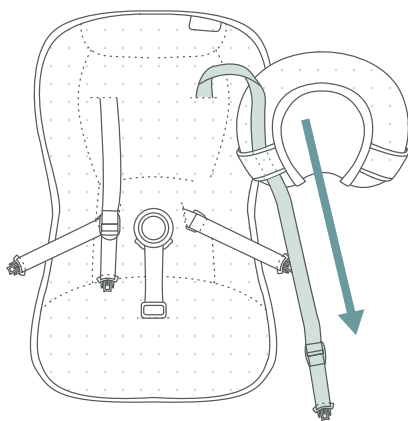

6. Thread each shoulder strap through the shoulder pads. Put the stroller crotch pad back onto the harness buckle.

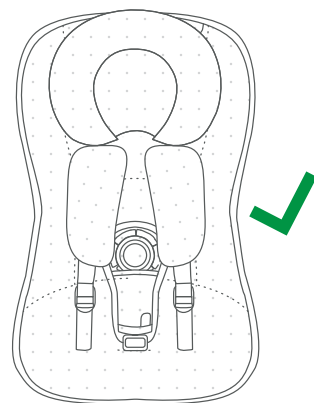

Removing the Newborn Insert Cushion

Note: When storing the Newborn Insert Cushion, take care to keep all parts together.

1. Remove the crotch pad from the harness buckle. Slide the shoulder pads off the shoulder straps. Remove the shoulder straps from the loops at the back of the head hugger.
2. Thread the harness buckle, hip and shoulder straps back through the liner.

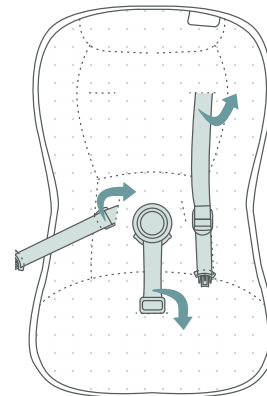
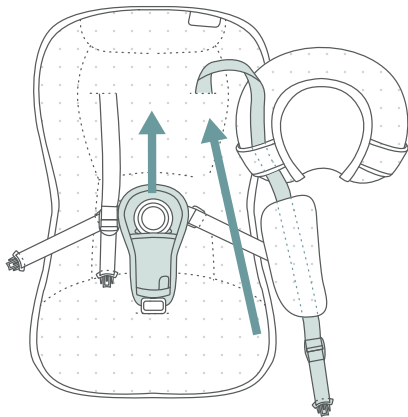

3. Remove the Newborn Insert Cushion from the stroller seat.

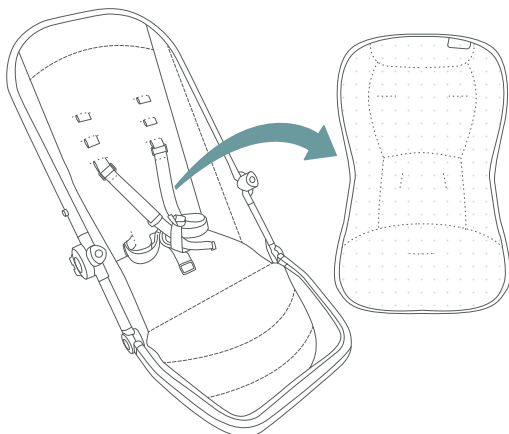

Adjusting the footrest

1. Locate the circular buttons on both sides of the footrest hinge.

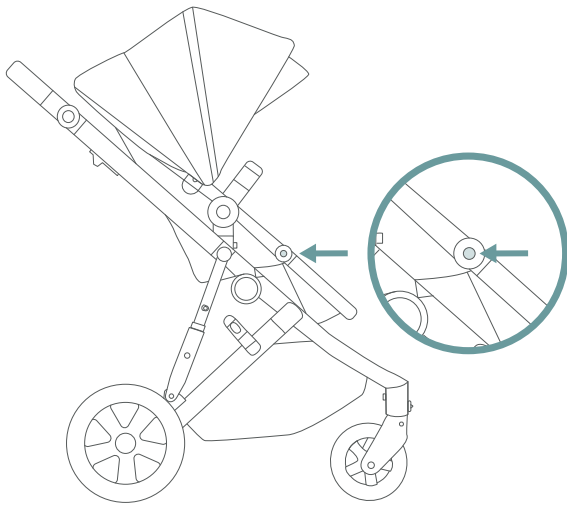

2. Press both buttons and simultaneously raise or lower the footrest to the desired position.

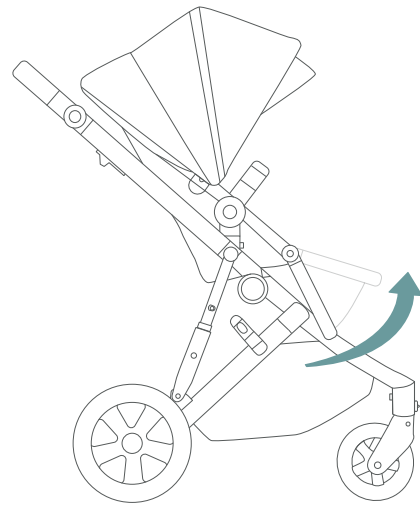

Adjusting the handlebar

Note: The handlebar has six height positions.

1. Locate the circular buttons on the outside of both sides of the handlebar.

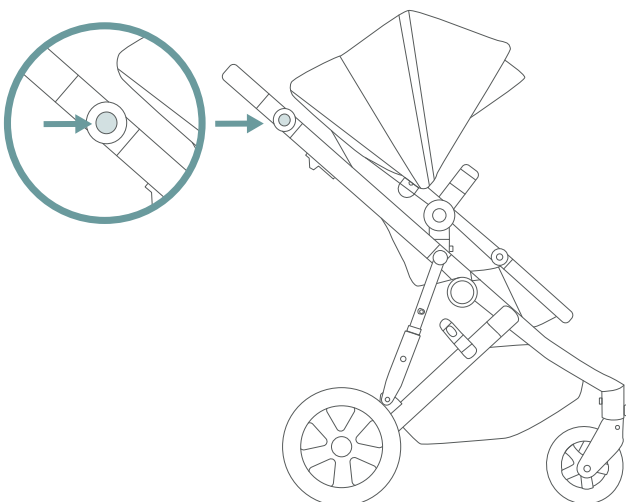

2. Press both buttons and simultaneously raise or lower the handlebar to the desired position.

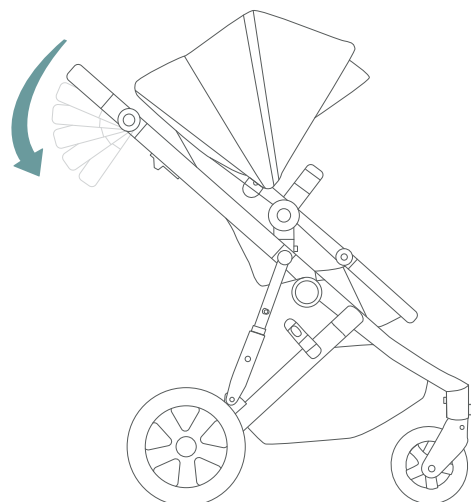

Using the harness buckle

Locking the buckle

1. Insert one harness tongue into the harness buckle until you hear a click.
2. Repeat step one for each of the remaining three harness tongues.

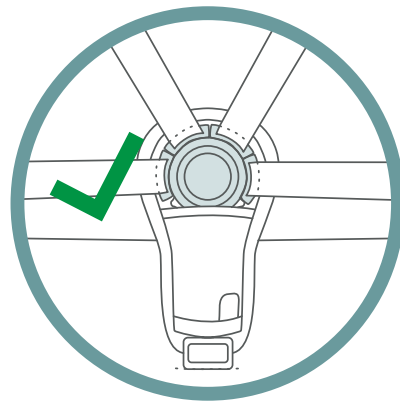
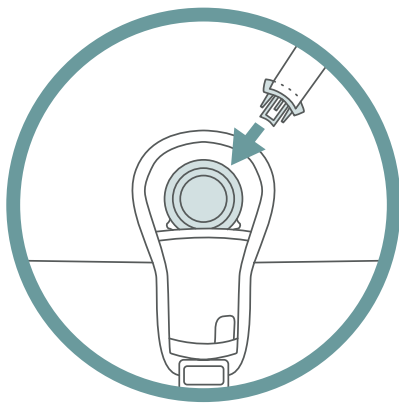

Unlocking the buckle

1. Push the button at the centre of the buckle.
2. Remove the four harness tongues.

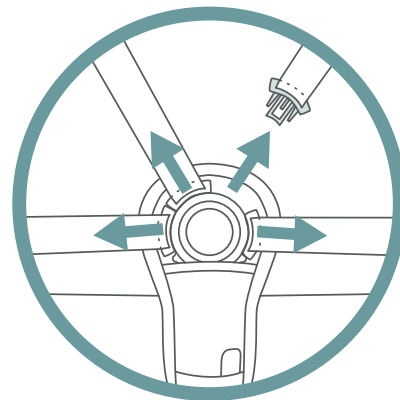
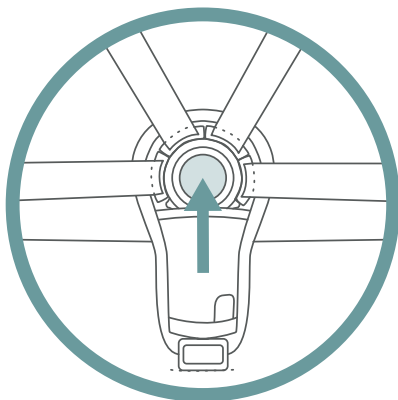

Adjusting the shoulder strap height

Note: There are three height positions for the shoulder straps. As your child grows, it is necessary to move the shoulder straps according to your child's height. The shoulder straps should be positioned at about level or just above your child's shoulders.

1. Locate the harness loops in the slots in the seat back.

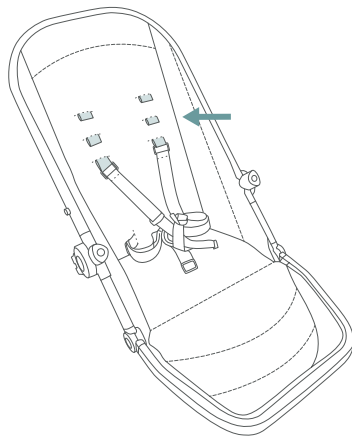

2. Pull the harness loops through to the front.

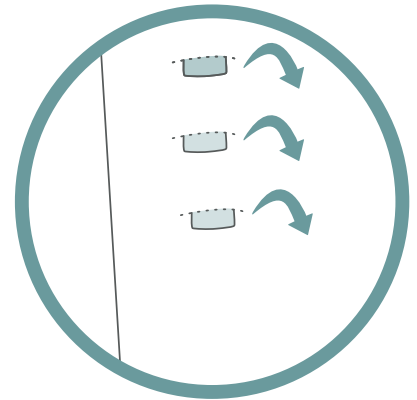

3. Locate the metal loops on the end of the shoulder straps. Thread these onto the harness loops at the required height.

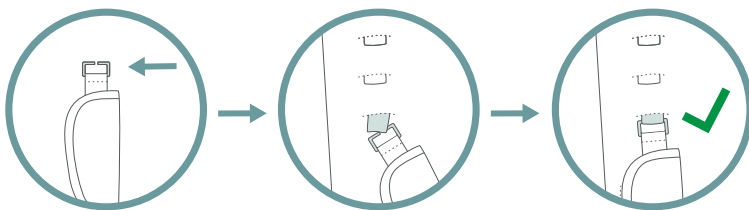

Correct fit for harness

Adjusting the harness straps

Note: The harness should be firm but not too tight around your child. It is adjusted correctly when you can fit two of your fingers between the harness and your child.

WARNING: Never leave a harness connected when not fitted to a child in the stroller. A connected harness can form loops which may be a strangulation hazard.

Adjusting the hip and shoulder straps

1. Pull the webbing straps through the toggle on the hip or shoulder straps and adjust to the desired length.

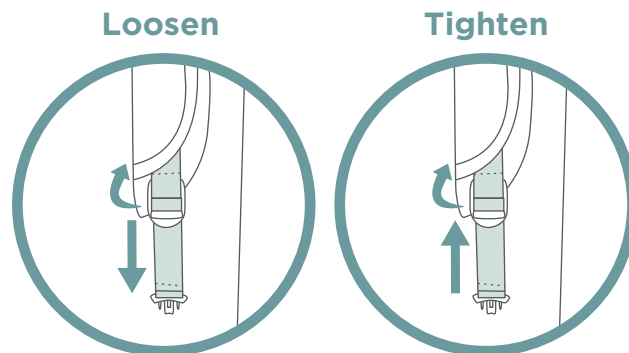

Adjusting the harness buckle strap

1. Pull the webbing straps through the toggle on the harness buckle strap and adjust to the desired length.



Correct fit for harness

Using the parking brake

Note: When the brake is engaged, the brake indicator window will show red. When the brake is released, the brake indicator window will show green.

Engaging the parking brake

1. Push the red brake pedal down with your foot.

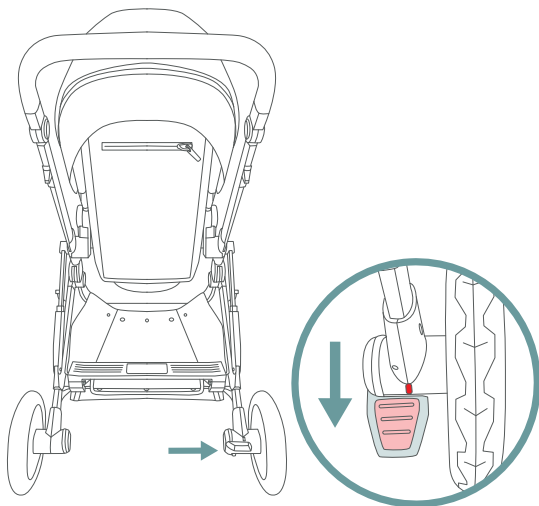

2. Ensure the brake has locked both rear wheels. Push the stroller a little to make sure the brake is engaged and working.

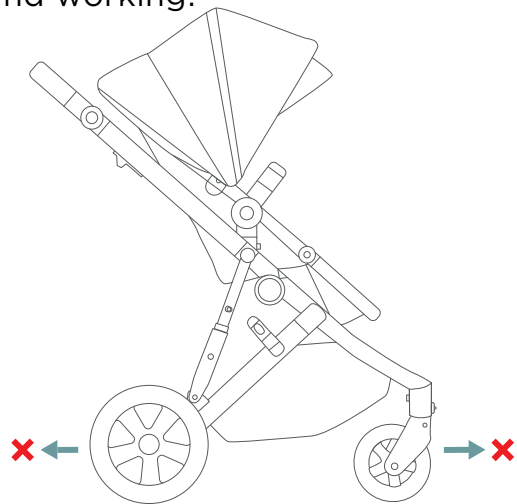

Releasing the parking brake

1. Push the red brake pedal down with your foot.

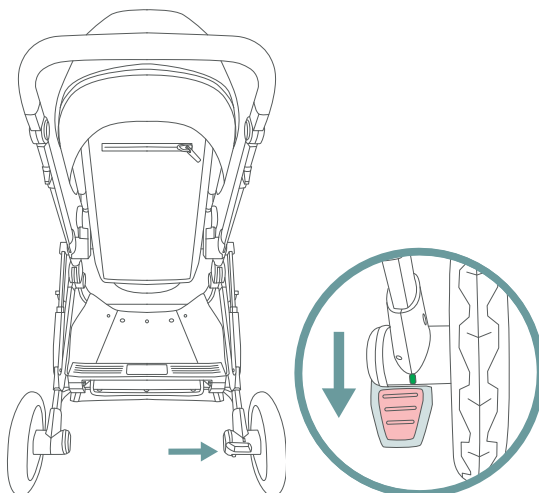

2. Ensure the brake has unlocked both rear wheels.

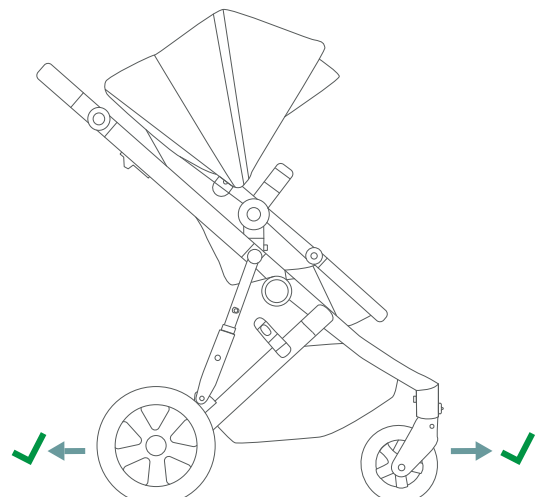

Using the front wheel swivel lock

Note: The swivel locks are used to lock the front wheels into position or to release the front wheels to enable them to swivel freely.

Engaging the front wheel swivel lock

1. Locate the swivel locks on the front wheel housing.

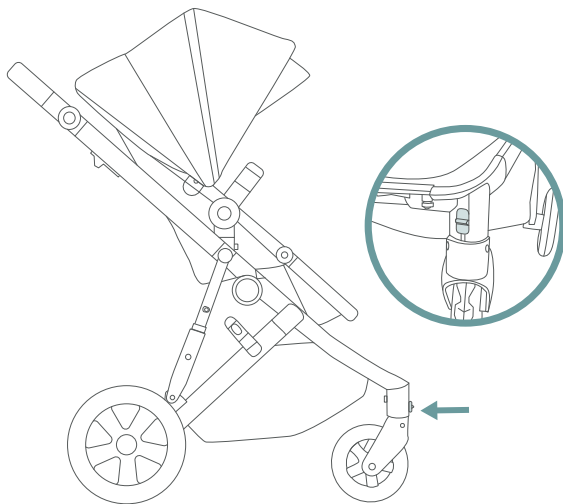

2. Slide the lock lever downwards on both front wheels.

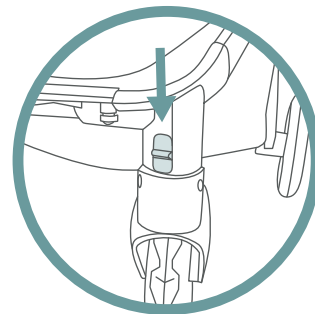

3. Swivel the front wheels until you hear the lock click into place.

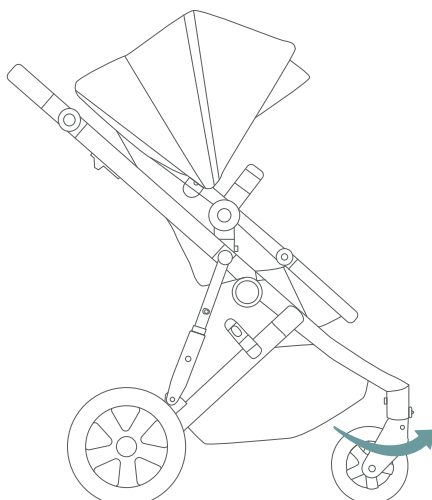

4. Push the stroller a little to make sure the front wheels are locked into position.

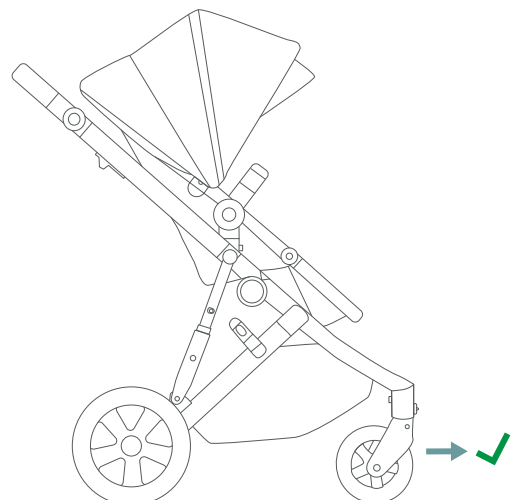

Unlocking the front wheel swivel lock

1. Slide the lock lever upwards on both front wheels.

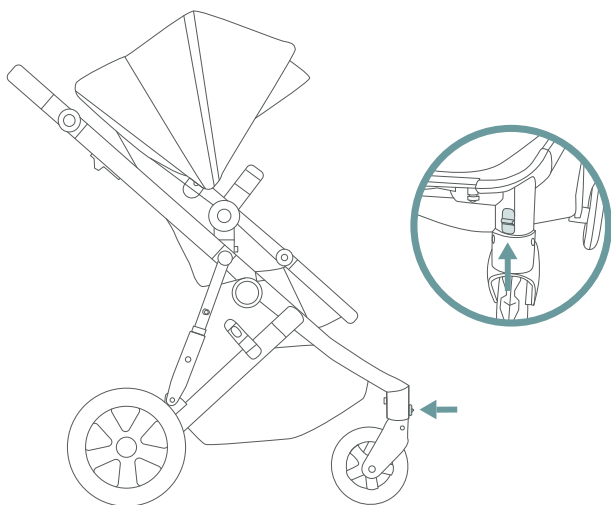

Carrying the stroller

Recommendation: When lifting the stroller, we recommend holding the frame on both sides near the fold hinge.

1. Hold the area near the fold hinge. Ensure the fold lock latch is secure.

- ✓ Check the fold lock latch is secure before you lift or carry the stroller.

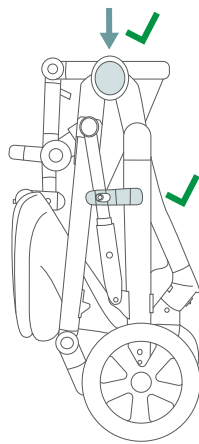

Note - If the fold lock latch does not engage, check the front wheels have not jammed. When folding, the front wheels should rotate away from the stroller for a proper fit. To correct it, unfold the stroller and fold again ensuring the wheels rotate as described.

Attaching cover for lower connection points

1. Locate the connection points located on the cross-bar at the rear of the stroller basket.

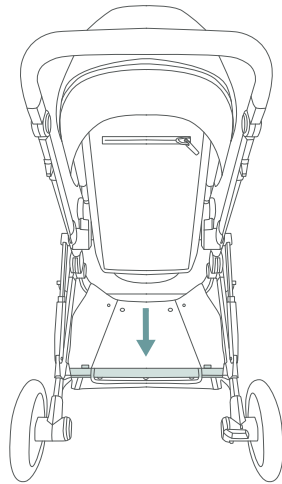

2. Align the cover on top of the connection points, keeping it parallel to the floor. Click it into place.

-  You will hear a click when the cover connects to the housing correctly.

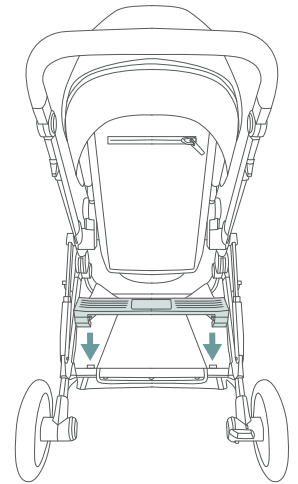

Removing cover for lower connection points

1. Locate the black release buttons below the cover, at both ends.

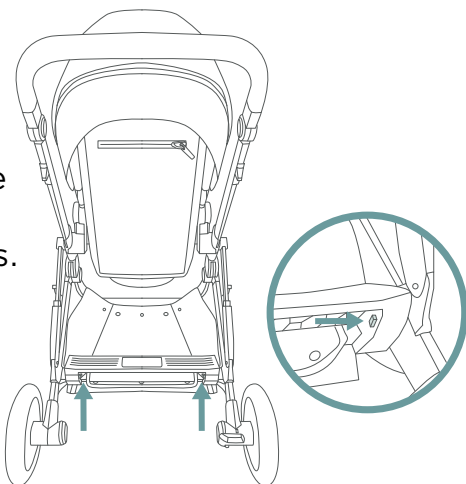

2. Press and hold one button while pulling the cover off. Repeat at the other end.

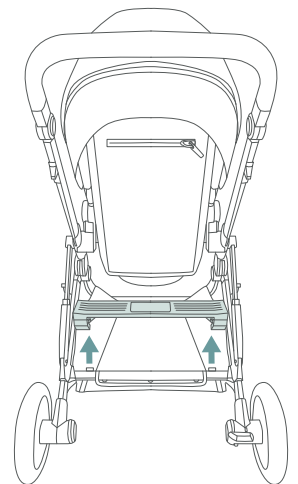

Using the Olive Second Seat Kit (sold separately)

The Olive Second Seat Kit is designed to convert Olive into a double stroller.

For detailed instructions, please read the Olive Second Seat Kit Use & Care Guide.

Using the upper adapters

Note: The stroller can be folded with the upper adapters connected.

Installing the upper adapters

1. Insert the upper adapters into the connection points on the stroller frame (R = Right; L = Left). Pull each adapter upwards to check they are both secure.

✔ You will hear a click when the adapters connect and lock correctly.

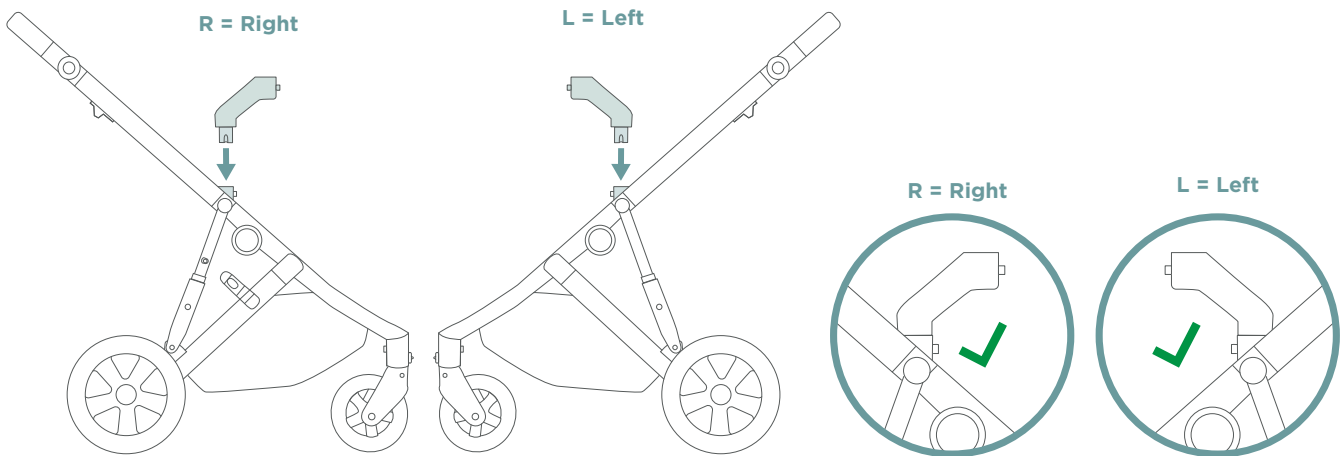

2. Attach desired accessory: main seat unit, Carry Cot, Aver! Capsule or capsule adapters for other model capsules.

Note: see Olive Use + Care Guide for detailed instructions for attaching and removing approved accessories.

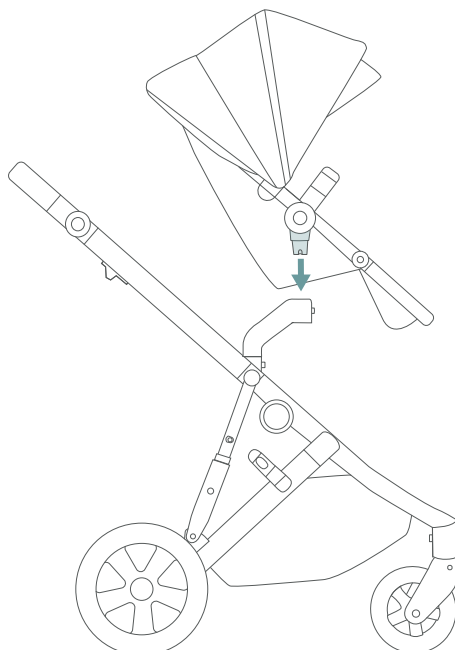

Removing the upper adapters

1. Locate the adapter release buttons on the stroller frame, just below the adapters' connection points.
2. Press the release buttons.

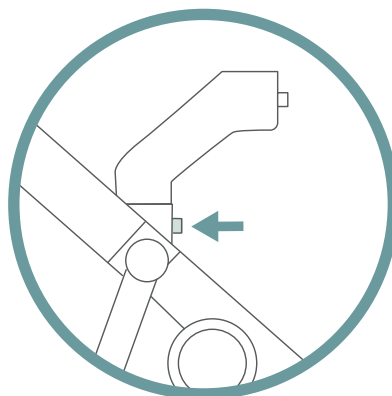
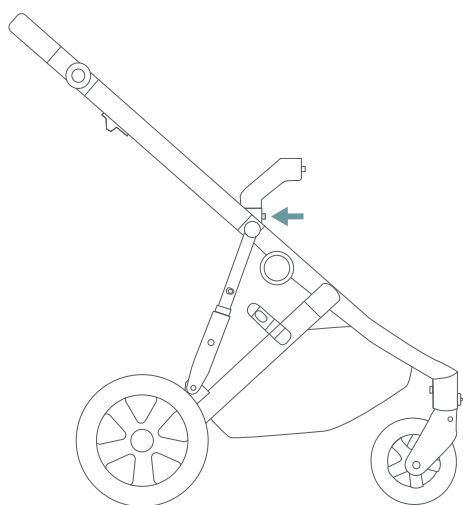

3. Lift the adapters out of the stroller frame.

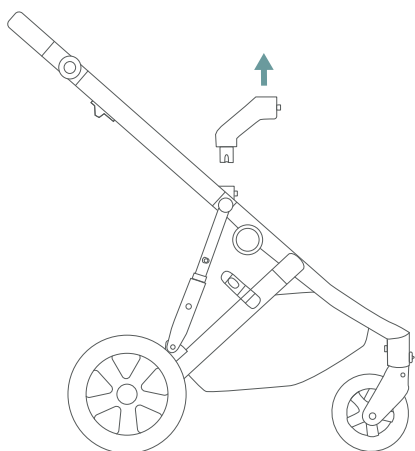

How to care for and maintain your stroller

Store your stroller and accessories carefully

Store inside in a well-ventilated, dry area.

Do not store in a damp environment that is not well insulated (such as an unfinished basement or outdoor shed).

Store when dry, not damp or wet.

Store away from direct sunlight. Direct sunlight could cause fabric fading or damage.

Store away from carpet. Rubber on the wheels could leave marks on carpet.

Do not place heavy objects on top of your stroller or accessories.

NEVER allow your stroller to come into contact with corrosive substances.

Examples are battery acid or petroleum products. Corrosion is not covered under our warranty - see the **Warranty** in this Instruction Manual.

NEVER immerse or soak or spray your stroller with water. Water can damage the internal mechanisms of your stroller, including the brake system.

Clean your stroller carefully

Use a damp cloth to clean the seat fabric and/or sun canopy. To dampen a cloth, dip the cloth in a small amount of mild detergent diluted in water (such as laundry liquid).

NEVER fully soak the cloth in water.

NEVER clean any part of the stroller with abrasive, ammonia-based, bleach-based or spirit-based cleaners.

See care labels for specific instructions regarding machine washing.

Dry your stroller carefully

Dry the stroller thoroughly before storing it.

NEVER tumble dry any part of the stroller.

NEVER wring any stroller fabrics.

Replace damaged or worn wheels immediately

Stop using the stroller if any wheel becomes damaged or worn. Replace it immediately.

Check regularly for wear and tear

Check regularly for wear and tear on all stroller parts.

Get your stroller inspected regularly

Get your stroller inspected regularly to maintain it. Regular inspection ensures the locking devices are working correctly and essential components are secure. Please read **How to service your stroller** in this Instruction Manual.

Use your stroller in sunlight for short periods

Always park your stroller in a shaded area. Only use your stroller in direct sunlight for short periods. This will help reduce fabric fading and damage.

Read our Servicing Guide before using the stroller on the beach or near salt water

If you live within 3kms of the sea, take extra care to park/store your stroller indoors and away from wind. Salt water carries in strong winds and is extremely corrosive.

Do not use your stroller on the beach. Salt and moisture can damage moving parts. Even salty atmospheric conditions can affect the stroller's mechanisms.

If you use your stroller in coastal areas, please read **How to service your stroller in this Use & Care Guide.**

How to service your stroller

Just like your car, regular service extends the life of your Edwards & Co stroller.

Inspect your stroller at least once a month

We recommend that you fully inspect your stroller at least once a month.

Here are some helpful tips to inspect your stroller at home.

Inspect all the rivets and screws that connect your stroller together

- Make sure all rivets and screws are clean, tight and secure.
- If corrosion is forming on any rivet or screw: Wipe the rivet or screw with a damp cloth. Leave the rivet or screw to dry overnight. Spray a rag with some WD-40. This applies an extra coating over the rivets and screws to help protect against corrosion.

Inspect the wheels

- Remove the front and rear wheels.
- Wipe the wheels with a clean rag to remove any dirt, sand or other debris.
- Wipe out the wheel housing.
- Rear wheels only: Spray the wheel pins with some WD-40. Spraying will help to keep the wheel release mechanism operating smoothly.

Inspect the fold joints

- Make sure the fold joints are free of dirt and debris.
- Wipe the fold joints clean with a damp cloth.
- Clean the fold joints when the stroller frame is folded.
- Apply some WD-40 or silicone spray (available at Bunnings, Mitre 10 or your local supermarket) to the moving hinges.

Inspect the metal components to help prevent rust

- Wipe down the frame and wheel housing with a damp cloth if the stroller has been:
 - on a beach
 - in the rain
 - in windy and exposed areas.
- If you live or use the stroller within 3kms of the beach or sea: Spray a cloth with WD-40 and wipe down all screws and rivets. This applies an extra coating over the rivets and screws to help protect against corrosion. Repeat this process monthly.

WARNING: Do not use the stroller on the beach. Sand and salt will interfere with moving parts.

WARNING: Do not immerse or rinse your stroller with water. Water can damage the internal parts of your stroller, including the brake system.

Service your stroller at least once every 6 months

We recommend you get your stroller serviced at least once every 6 months.

To get your stroller serviced, contact us at hello@edwardsandcobaby.com

Our customer service team will offer assistance or make an appointment for you to visit our service team at our main office in Silverdale, Auckland.

We also host service days at retailers throughout New Zealand multiple times a year.

You will find the list of service days on our Events page within our website.

Warranty

All Edwards & Co products are guaranteed for two years from the date of shipping against defects in material and workmanship.

If we determine that the product has a manufacturing fault, we will repair or replace it free of charge to you. The decision to repair or replace is solely at the discretion of Edwards & Co Proof of purchase must be provided.

The warranty is “return to base” and not a free in-home service. This means the customer is responsible for any inwards freight charge to return the product to an Edwards & Co representative for warranty or service.

Our warranty excludes claims resulting from misuse, abnormal use, overloading, general wear and tear (including scratches), child outgrowing the product, not following instructions, transportation damage (including airline or freight damage), poorly maintained product, dropped goods, negligence, second-hand product, modified product, colour fading, over inflation, mould, damage to handle foam in use or fabric cuts and tears. Our warranty also does not cover tyre punctures or corrosion to frames or fasteners as a result of atmospheric or environmental conditions.

Any replacement will not give the right for the warranty period to be extended.

Edwards & Co does not cover warranty if the product has been purchased second hand or from an unauthorised reseller.

For the complete terms and conditions of our warranty, please visit our website – edwardsandco.nz/pages/warranty

Edwards & Co New Zealand

Unit 5
30 Foundry Road
Silverdale 0932
NEW ZEALAND
NZ: (09) 869 8950
hello@edwardsandcobaby.com

Edwards & Co Australia

C/O - G&S Logistics
Unit 1, 96-112 Gow Street
Padstow NSW 2211
AUSTRALIA
AU: (02) 9066 6702

This page is intentionally blank

Designed with love

Watch helpful
instructional videos



Come along on
the journey



Visit our comprehensive support centre online

edwardsandcobaby.zendesk.com/hc/en-us
