

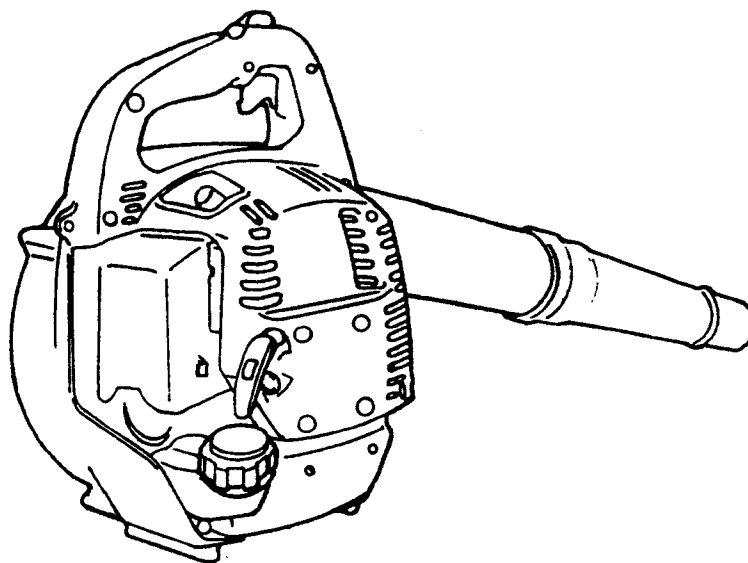

Blower/Vacuum

RBL250
RBLV250

INSTRUCTION MANUAL



Important:
Read this instruction manual carefully before putting the
Blower into operation and strictly observe the safety
regulations!
Preserve instruction manual carefully!

Thank you very much for selecting the MAKITA blower. We are pleased to be able to offer you the MAKITA blower which is the result of a long development programme and many years of knowledge and experience.

The blower models RBL250 and RBLV250 combine the advantages of state-of-the-art technology with ergonomic design, they are light weight, handy, compact and represent professional equipment for a great variety of applications.

Please read, understand and follow this booklet which refers in detail to the various points that will demonstrate its outstanding performance. This will assist you to safely obtain the best possible results from you MAKITA blower.



Table of Contents	Page
Symbols	2
Safety instructions	3 - 6
Technical data	7
Designation of parts	8
Assembly instructions	9
Assembly of blower pipes	9
Assembly of vacuum attachment	9 - 10
Fuels/Refuelling	11
Blower operation	12
Idle adjustment	13
Servicing instructions	13 - 14
Maintenance schedule	15
Storage	15
Troubleshooting procedures	15

Symbols

It is very important to understand the following symbols when reading this instructions manual.

	WARNING/DANGER		Fuel and Oil Mixture
	Read, Understand and Follow Instruction Manual		Engine-manual Start
	Forbidden		Emergency Stop
	No Smoking		First Aid
	No Open Flame		Recycling
	Protective Gloves must be Worn		ON/START
	Keep the Area of Operation Clear of All Persons and Pets		OFF/STOP
	Wear Eye and Ear Protection		EC-mark

SAFETY INSTRUCTIONS

General instructions

- To ensure correct and safe operation, the user must read, understand and follow this instruction manual to assure familiarity with the handling of the blower (1). Users insufficiently informed will risk danger to themselves as well as others due to improper handling.
- It is recommended only to loan the blower to people who have proven to be experienced with blowers. Always hand over the instruction manual.
- First-time users should ask the dealer for basic instructions to familiarize oneself with the handling of a blower.
- Children and young persons aged under 18 years must not be allowed to operate the blower. Persons over the age of 16 years may however use the tool for the purpose of being trained only while under the direct supervision of a qualified trainer.
- Use blowers with the utmost care and attention.
- Operate the blower only if you are in good physical condition. Perform all work conscientiously and carefully. The user has to accept responsibility for others.
- Never use the blower while under the influence of alcohol or drugs (2).
- Do not use the blower when you are tired.
- **Save these instructions for future referral.**

Personal protective equipment

- The clothing worn should be functional and appropriate, i. e. it should be tight-fitting but not cause a hinderance. Do not wear jewelry, clothing or long hair which could be drawn into the air intake.
- In order to avoid head-, eye-, hand- or foot injuries as well as to protect your hearing the following protective equipment and protective clothing must be used during operation of the blower.

Pay particular attention to the following regulations:

- Clothing must be sturdy and snug-fitting, but allow complete freedom of movement. Avoid loose-fitting jackets, flared or cuffed pants, scarfs, unconfined long hair or anything that could be drawn into the air intake. Wear overalls or long pants to protect your legs. Do not wear shorts. (4)
- Blower noise may damage your hearing. Wear sound barriers (ear plugs or ear muffers) to protect your hearing. Continual and regular users should have their hearing checked regularly. (3)
- Use of gloves when working with the blower is recommended. Good footing is most important. Wear sturdy shoes with nonslip soles. (4)
- Proper eye protection is a must. Even though the discharge is directed away from the operator, ricochets and bouncebacks can occur during blower operations. (3)
- Never operate a blower unless wearing goggles or properly fitted safety glasses with adequate top and side protection.

Starting up the blower

- Please make sure that there are no children or other people within a working range of 15 meters (5), also pay attention to any animals in the working vicinity. Never use the blower in urban areas.
- **Before operating, always check that the blower is safe for operation:**
Check the security of the throttle lever. The throttle lever should be checked for smooth and easy action. Check for proper functioning of the throttle lever lock. Check for clean and dry handles and test the function of the ON/OFF switch. Keep handles free of oil and fuel.

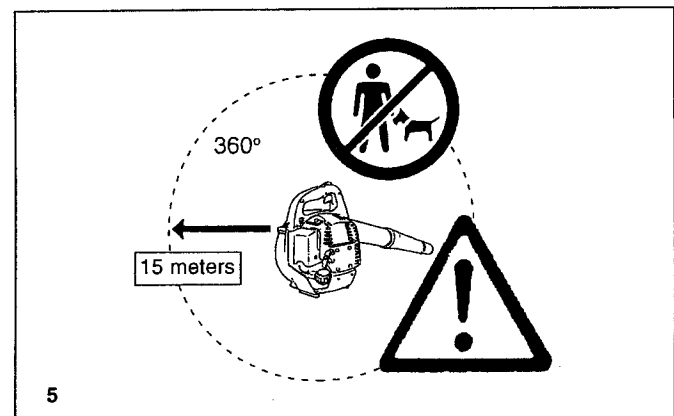
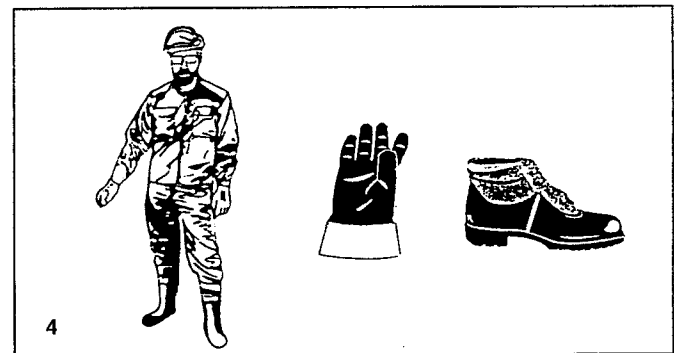
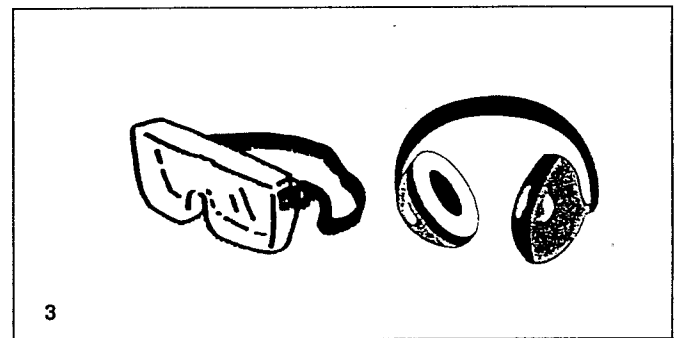
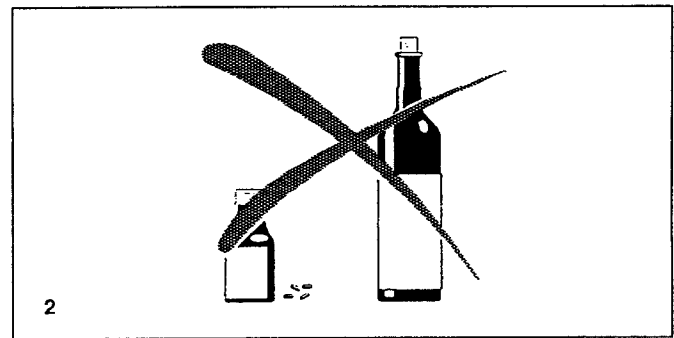
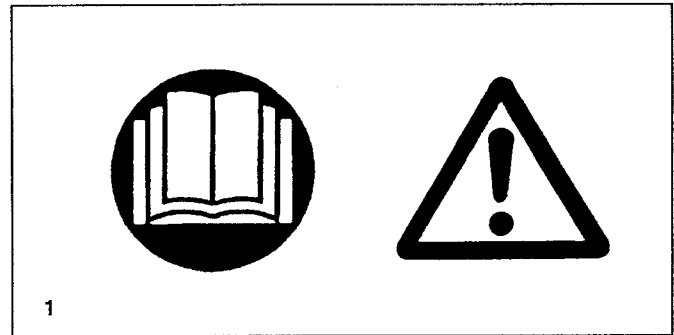

Start the blower only in accordance with the instructions.

Do not use any other methods for starting the engine (6)!

- Use the blower and the tools supplied only for applications specified.
- **Start the blower engine only after the entire assembly is done. Operation of the tool is permitted only after all the appropriate accessories are attached!**
- The engine is to be stopped immediately if there are any engine problems.
- When working with the blower, always wrap your fingers tightly around the handle, keeping the control handle cradled between your thumb and forefinger. Keep your hand in this position to have your machine under control at all times. Make sure your control handle (and grip for vacuum attachment) are in good condition and free of moisture, pitch, oil or grease.
- **Always ensure a safe, well-balanced footing.**
- Only use outdoors.
- Operate the blower in such a manner as to avoid inhalation of the exhaust gases. Never run the engine in enclosed rooms (risk of suffocation and gas poisoning). Carbon monoxide is an odorless gas. Always ensure there is adequate ventilation.
- Stop the engine when resting and when leaving the blower unattended. Place it in a safe location to prevent danger to others, setting fire to combustible materials, or damage to the machine.
- Never lay the hot blower onto dry grass or onto any combustible materials.
- Never operate the engine with a faulty exhaust muffler.
- Stop the engine during transport (7).
- Position the blower safely during car or truck transportation to avoid fuel leakage.
- When transporting the blower, ensure that the fuel tank is completely empty.

Refuelling

- Stop the engine before refuelling (7), keep well away from open flame (8) and do not smoke.
- Do not attempt to refuel a hot or a running engine.
- Avoid skin contact with petroleum products. Do not inhale fuel vapor. Always wear protective gloves during refuelling. Change and clean protective clothing at regular intervals.
- Take care not to spill either fuel or oil in order to prevent soil contamination (environmental protection). Clean the blower immediately after fuel has been spilled. Allow wet cloths to dry before disposing in proper, covered container to prevent spontaneous combustion.
- Avoid any fuel contact with your clothing. Change your clothing immediately if fuel has been spilled on it (danger hazard).
- Inspect the fuel cap at regular intervals making sure that it stays securely fastened.
- Carefully tighten the locking screw of the fuel tank. Change locations to start the engine (at least 3 meters away from the place of refuelling) (9).
- Never refuel in closed rooms. Fuel vapors accumulate at ground level (risk of explosions).
- Only transport and store fuel in approved containers. Make sure stored fuel is not accessible to children.
- When mixing gasoline with two-cycle engine oil, use only gasoline which contains no ethanol or methanol (types of alcohol). This will help to prevent damage to fuel lines and other engine parts.

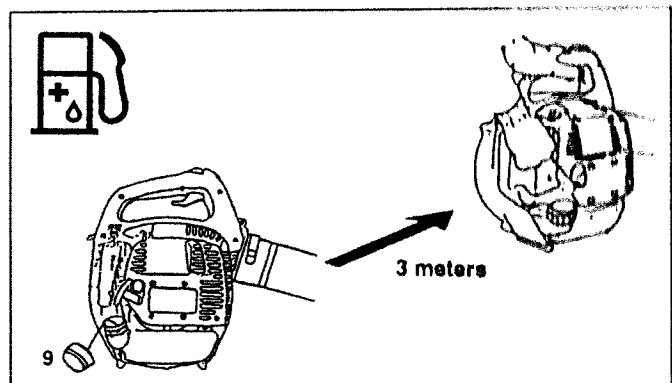
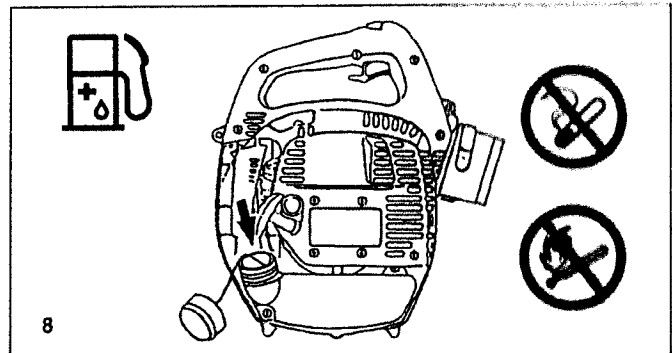
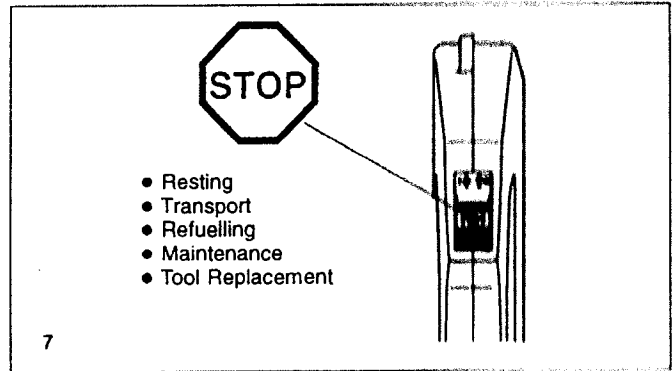
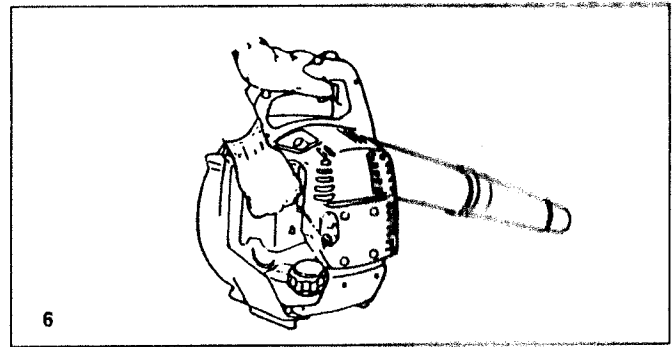

Method of operation

- Use the blower only in good light and visibility. During cold seasons beware of slippery or wet areas, ice and snow (risk of slipping). Always ensure a safe footing.
- Never work on unstable surfaces or steep terrain.
- To reduce the risk of personal injury, do not direct air blast towards bystanders, since the high pressure of the air flow could injure eyes and could blow small objects at great speed.
- Never insert any foreign object into the air intake of the machine or into the nozzle of the blower. It will damage the fan wheel and may cause serious injury to the operator or bystanders as a result of the object or broken parts being thrown out at high speed.
- Pay attention to the direction of the wind, i.e., do not work against the wind.
- To reduce the risk of stumbling and loss of control, do not walk backward while operating the machine.
- Always stop the engine before cleaning or servicing the unit or replacing parts.

Maintenance instructions

- Be kind to the environment. Operate the blower with as little noise and pollution as possible. In particular check the correct adjustment of the carburetor.
- Clean the blower at regular intervals and check that all screws and nuts are securely tightened.
- Never service or store the blower in the vicinity of open flames, sparks, etc (11).
- Always store the blower in a well-ventilated locked room and with an emptied fuel tank.

Observe and follow all relevant accident prevention instructions issued by the trade associations and by insurance companies. Do not perform any modifications to the blower as this will risk your safety.

The performance of maintenance or repair work by the user is limited to those activities as described in this instruction manual. All other work is to be done by Authorized Service Agents. Use only genuine spare parts and accessories supplied by MAKITA. Use of non-approved accessories and tools means increased risk of accidents and injuries. MAKITA will not accept any liability for accidents or damage caused by the use of any non-approved accessories.

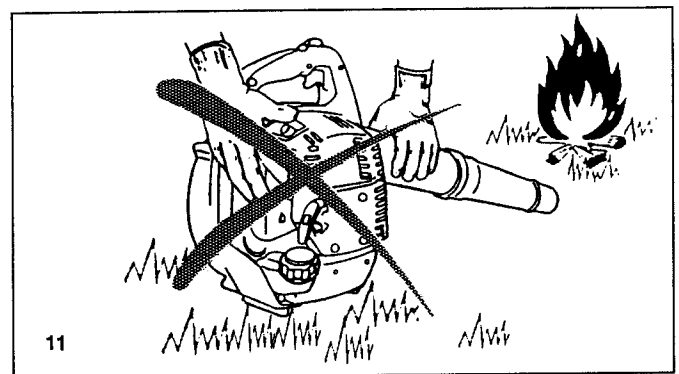
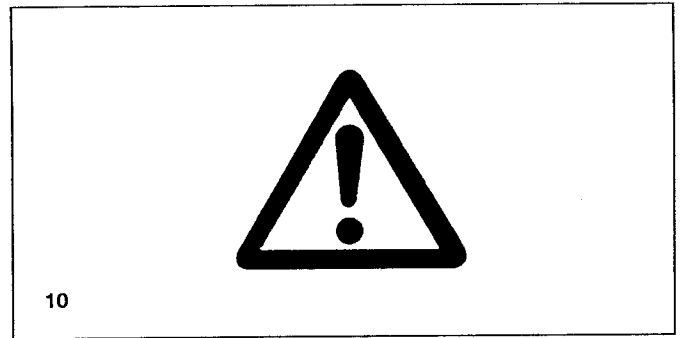

First Aid

In case of accident make sure that a well-stocked first-aid kit according to DIN 13164, is available in the vicinity of the cutting operations. Immediately replace any item taken from the first aid kit.

When asking for help, please give the following information:

- Place of accident
- What happened
- Number of injured persons
- Extent of injuries
- Your name

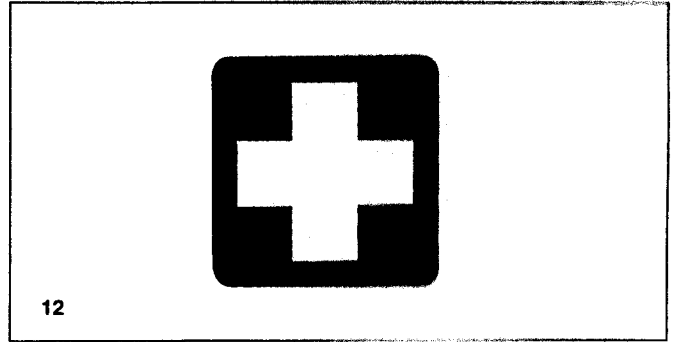

Packaging

The MAKITA blower is delivered in a protective cardboard box to prevent shipping damage. Cardboard is a basic raw material and is therefore consequently reusable or suitable for recycling (waste paper recycling).



EC-DECLARATION OF CONFORMITY

Model; RBL250, RBLV250

We declare under our sole responsibility that this product is in compliance with the following standards of standardized documents, EN292, EN55012 in accordance with Council Directives, 89/392/EEC, amended 98/37/EEC, 93/68/EEC, 89/336/EEC, amended 92/31/EEC.

Measured Sound Power: 100 dB

Guarantee Sound Power: 105 dB

These sound power levels were measured in accordance with Council Directive, 2000/14/EC.

Conformity assessment procedure: Annex V.

CE2007



Tomoyasu Kato
Director

Responsible Manufacturer:

Makita Corporation.

3-11-8, Sumiyoshi-cho, Anjo, Aichi, JAPAN

Authorized Representative in Europe:

Makita International Europe Ltd.

Michigan Drive, Tongwell, Milton Keynes, Bucks MK15 8JD, ENGLAND

Technical data

Model		RBL250	RBLV250
Dimensions: length x width x height (without blower pipes)	mm	355 x 235 x 340	355 x 320 x 340
Mass (with blower pipes)	kg	3.8	4.0
Engine displacement	cm ³	24.5	
Bore	mm	34	
Stroke	mm	27	
Volume (fuel tank)	cm ³	530	
Mixture ratio (Fuel : MAKITA 2-stroke oil)		50:1	
Carburetor (Diaphragm-carburetor)	type	WALBRO WYL	
Maximum engine speed	rpm	7,000	
Idling speed	rpm	2,600	
Ignition system	type	Solid state ignition	
Spark plug	type	NGK-BMR7A	
Electrode gap	mm	0.6 - 0.7	
Vibration per ISO 8662	m/s ²	9.01	
Sound pressure level average to ISO 6081	dB(A)	86.8	
Sound power level average to ISO 3744	dB(A)	95.7	

Designation of parts

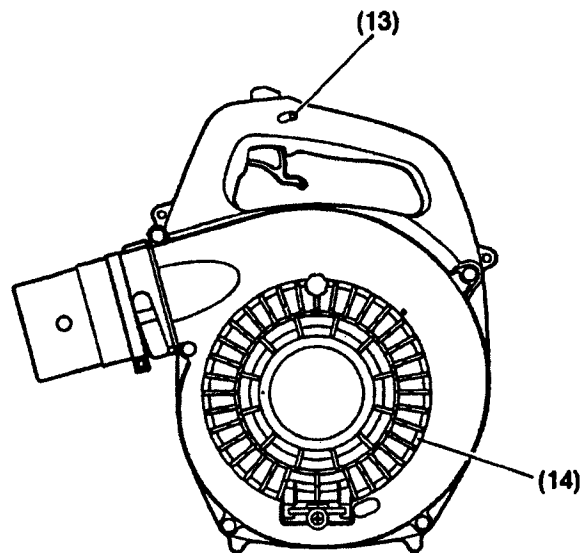
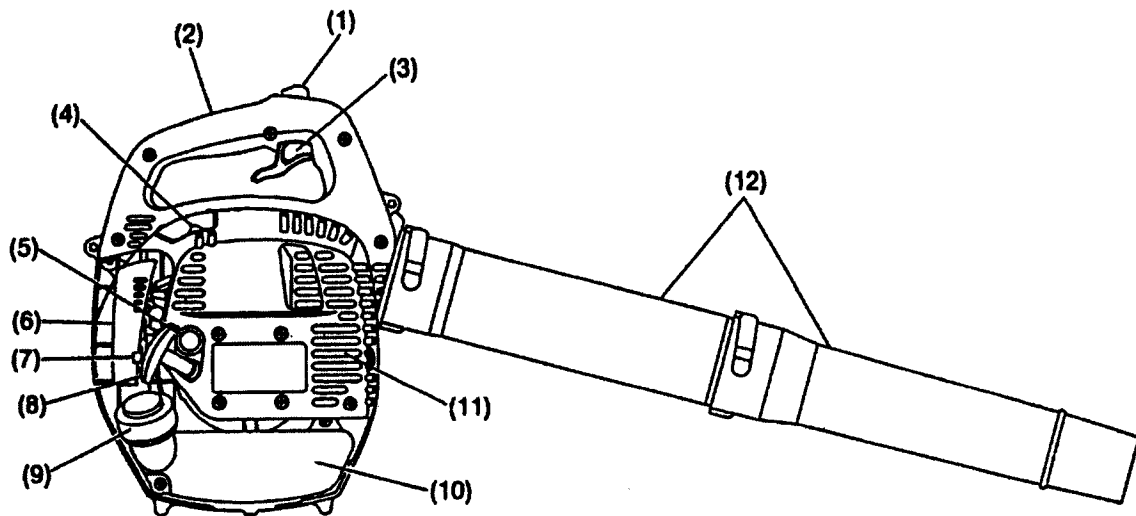

DESIGNATION OF PARTS		DESIGNATION OF PARTS		DESIGNATION OF PARTS	
1	I-O Switch	7	Choke Lever	13	Lock Button
2	Handle	8	Starter Knob	14	Protector
3	Throttle Lever	9	Fuel Filler Cap		
4	Spark Plug	10	Fuel Tank		
5	Primer Pump	11	Muffler		
6	Air Cleaner	12	Blower Pipe		

Assembly instructions



CAUTION: Before performing any work on the blower, always switch off the motor and pull the spark plug connectors off the spark plug. Always wear protective gloves!

CAUTION: Start the blower only after having assembled it completely.

1. Assembly of blower pipes

- 1) Align grooves in the blower pipe with pegs on the blower housing and slide the pipe onto housing.
- 2) Turn the blower pipe clockwise to lock it into place.

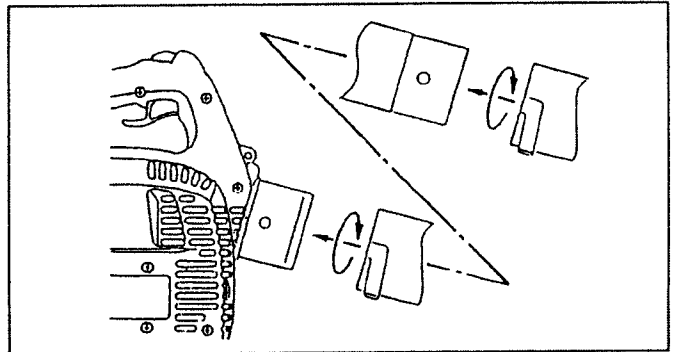

2. Assembly of vacuum attachment (Optional)

1) Installing Grip

- (1) Remove the four screws (1).
- (2) Install the screws (2), grip (3), spacers (4) and caps (5) provided on the blower as shown in the figure.
- (3) Tighten the screws (2) securely.

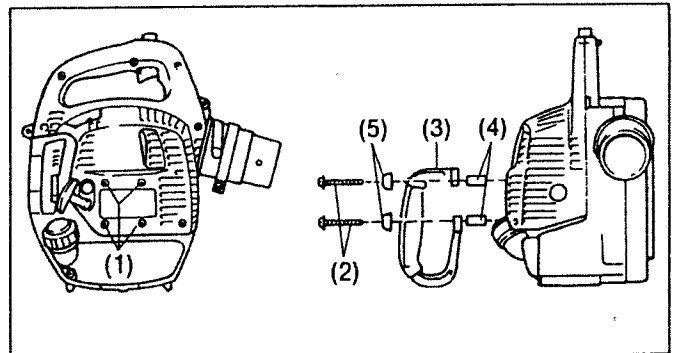

2) Installing Vacuum Pipe (nozzle)

- (1) First, remove the screw (6)

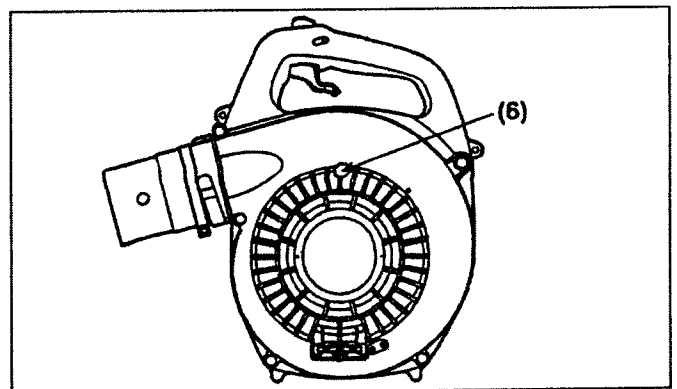

- (2) Align the (10) indicated on the vacuum pipe (9) with the indicated on the blower. Then insert the vacuum pipe (9) into the blower.
- (3) Turn the vacuum pipe (9) until the (10) is aligned with the indicated on the blower to lock the vacuum pipe.

CAUTION: Hold the bottom of the vacuum pipe when turning the vacuum pipe to install or remove it.

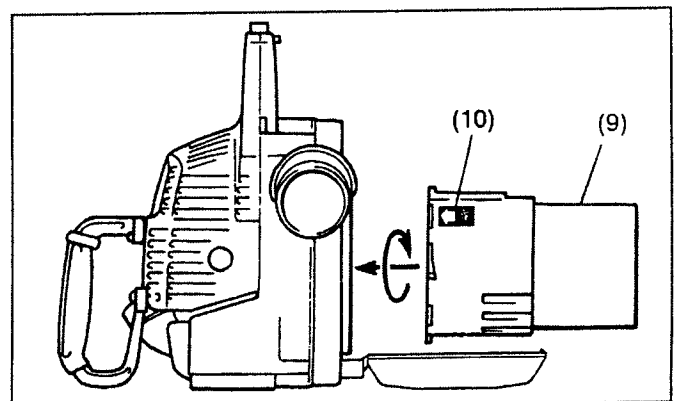

3) Installing Elbow and Dust Bag

- (1) Open the fastener of the dust bag.
- (2) Insert the elbow into the dust bag and take it out through the bag's entry. Secure the elbow with the velcro band.

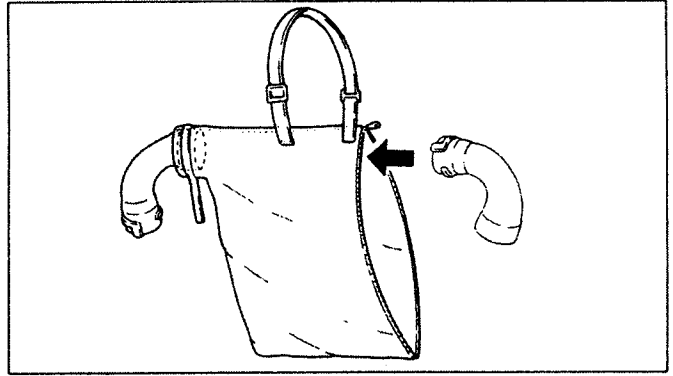

- (3) Install the elbow on the blower.

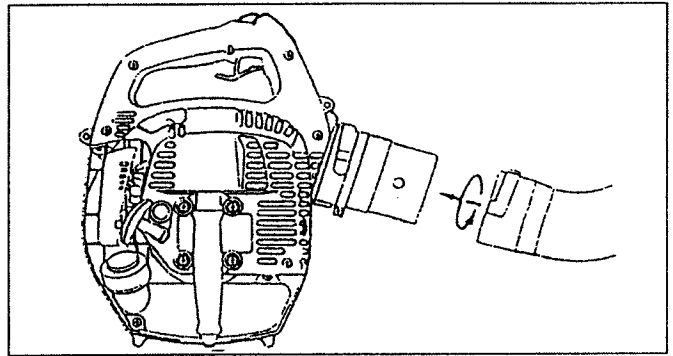

WARNING! Do not attempt to pick up large wood chips, metals, glass, stones, liquids, lighted cigarettes, fire works or the like.

Fuels/Refuelling

Handling petroleum products

Utmost care is required when handling fuel. Fuel may contain substances similar to solvents. Refuel either in a well ventilated area or outdoors. Do not inhale fuel vapors, avoid any contact of fuel or oil with your skin.

Mineral oil, fuel, etc., product degrease your skin. If your skin comes in contact with these substances repeatedly or for an extended period of time, various skin diseases may result. In addition, allergic reactions are known to occur. Eyes can be irritated by contact with oil, fuel etc.

If oil, fuel, etc., comes into your eyes, immediately wash them with clear water. If your eyes are still irritated, see a doctor immediately!

Fuel and oil mixture

The engine of the blower is a high-efficiency two-stroke engine. It is run with a mixture of fuel and two-stroke engine oil. The engine is designed to use unleaded regular fuel with a min. octane value of 91 RON. If no such fuel is available, you can use fuel with a higher octane value. This will not affect the engine, but may cause poor operating behavior.

A similar situation will arise from the use of leaded fuel. To obtain optimum engine performance and to protect your health and the environment, only unleaded fuel should be used!

For engine lubrication use a two-stroke engine oil (quality grade:TC-3), which is added to the fuel. The engine has been designed to use MAKITA two-stroke engine oil at mixture ratio of 50:1 to protect the environment. In addition, a long service life and reliable operation with a minimum emission of exhaust gasses is assured. It is absolutely essential to observe a mixture ratio of 50:1 MAKITA 2-stroke engine oil. Otherwise reliable function of the blower cannot be guaranteed.

The correct mixture ratio:

Mix 50 parts gasoline with 1 part MAKITA 2-stroke engine oil (see table on right).

NOTE: For preparing the fuel-oil mixture first mix the entire oil quantity with half of the fuel required in an approved can which meets or exceeds all local code standards, then add the remaining fuel. Thoroughly shake the mixture before filling it into the blower tank. It is not wise to add more engine oil than specified to ensure safe operation. This will only result in a higher production of combustion residues which will pollute the environment and clog the exhaust channel in the cylinder, the spark plugs as well as the muffler. In addition, fuel consumption will rise and the performance will be decreased.

Refuelling

Never perform refuelling operations in a closed, unventilated area.

The engine must be stopped and cooled down!

- Thoroughly clean the area around the gas cap, to prevent dirt from getting into the fuel tank.
- Unscrew the gas cap and fill the tank with fuel.
- Never fill the fuel tank to the very top.
- Securely screw on the gas cap.
- Wipe the screw plug and tank with an absorbent after refuelling! Allow cloths to dry and discard in a proper container.

Storage of Fuel

Fuel cannot be stored for an unlimited period of time. Purchase only the quantity required for a 4 week operating period. Only use approved fuel storage containers.



Observe the Safety Instructions on page 4

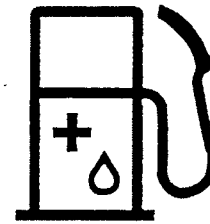

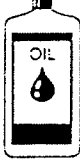
Gasoline (premium unleaded)	50:1
	
1,000 cm ³ (1 liter)	20 cm ³
5,000 cm ³ (5 liters)	100 cm ³
10,000 cm ³ (10 liters)	200 cm ³

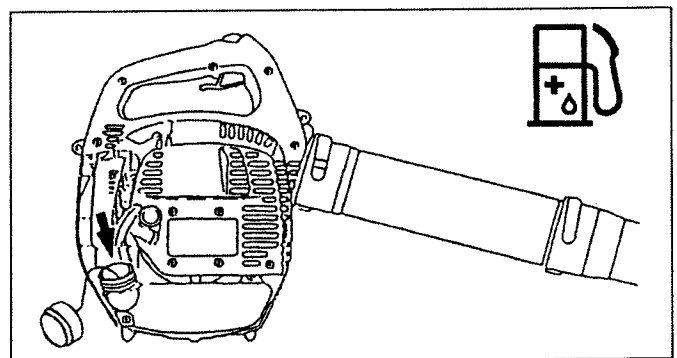

Blower operation



Observe all applicable accident prevention regulations!

Starting

Move at least 3 m away from the place of refuelling. Place the blower on an open area of ground taking care that the air flow does not blow objects. Make sure that this area is clear of combustible materials.

1. When the engine is cold, left stopped for more than 5 minutes or when fuel is added to the engine:
 - 1) Push the I-O switch (1) to "I" position.
 - 2) Give a gentle push on the primer pump repeatedly (7 – 10 times) until fuel comes into the primer pump (2).
 - 3) Close the choke lever fully by moving it to the |↖| position (3).
 - 4) Lock the throttle lever in the "start-up" position as follows. Squeeze the throttle lever (4) fully. Then push the lock button (5). Release the throttle lever while pushing the lock button.
- 5) Place the blower on the ground. Hold the handle with your left hand and give several strong pulls to the starter by your right hand.
- 6) After the engine is started, open the choke lever fully by moving it gradually to the |↑| position.
- 7) Release the throttle lever fully.

NOTE: The throttle lever is unlocked when squeezing it slightly.

2. Restarting immediately after the engine has stopped:
 - 1) Push the I-O switch (1) to "I" position.
 - 2) Give a gentle push on the primer pump repeatedly (7 – 10 times) until fuel comes into the primer pump (2).
 - 3) Open the choke lever fully by moving it to the |↑| position (3).
 - 4) Leave the throttle lever fully released.
 - 5) Place the blower on the ground. Hold the handle with your left hand and give several strong pulls to the starter by your right hand.

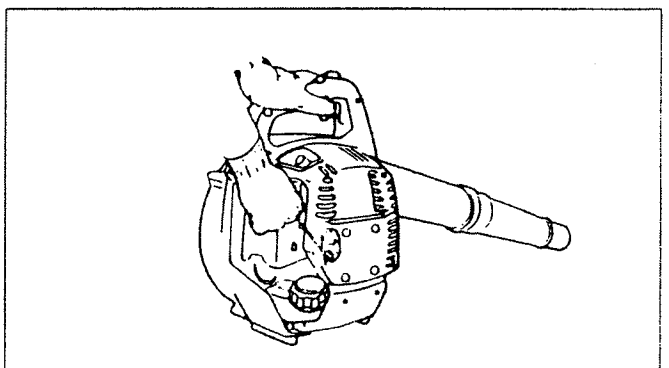
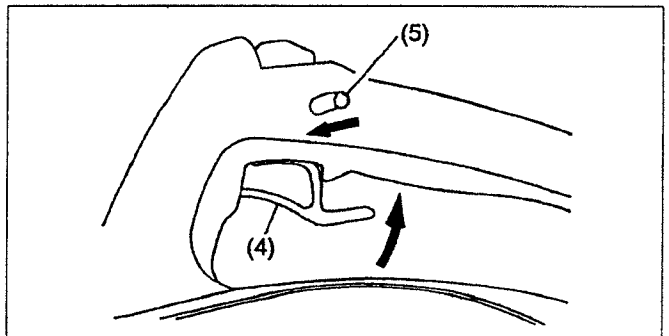
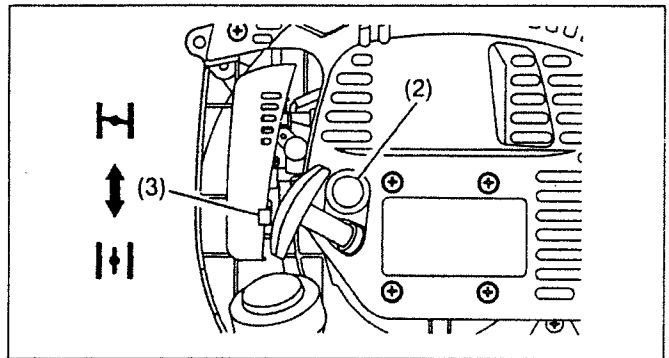
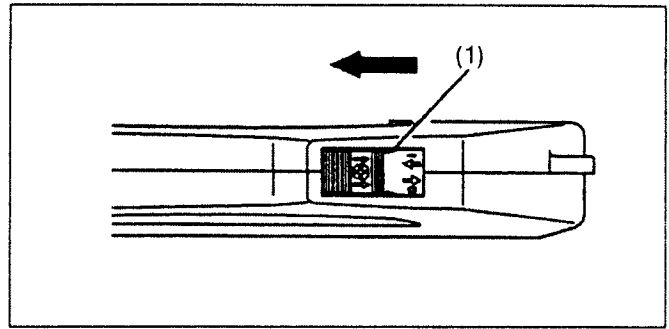

Stopping

- Release the throttle lever fully, and when the engine rpm has lowered, push the I-O switch to "O" position. Engine will stop.

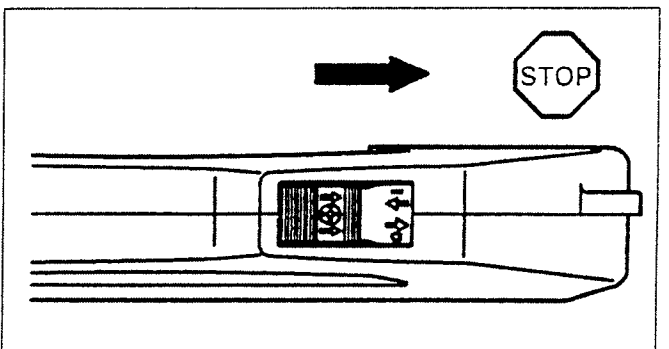

Idle adjustment

- If engine stops while idling, turn the idle adjusting screw (1) clockwise until the engine runs smoothly.

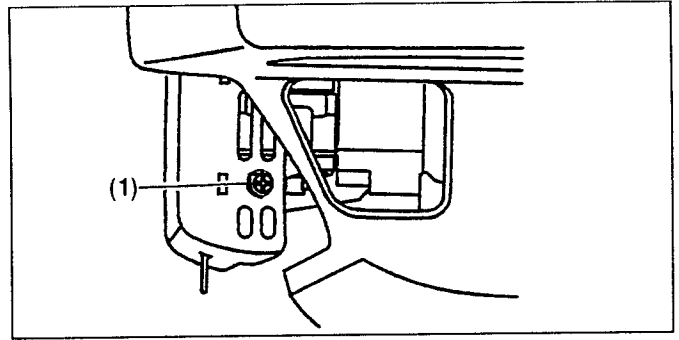

Servicing instructions



CAUTION: Before doing any work on the blower always switch off the motor and pull the plug caps off the spark plugs (see "Checking the spark plugs" page 14).
Always wear protective gloves!

To ensure a long service life and to avoid any damage to the equipment, the following servicing operations should be performed at regular intervals.

Daily checkup and maintenance

- Before operation, check the machine for loose screws or missing parts.
- Before operation, always check for clogging of the cooling air passage and the cylinder fins. Clean them if necessary.
- Perform the following maintenance daily after use:
 - Clean the blower externally and inspect for damage.
 - Clean the air filter. When working under extremely dusty conditions, clean the filter and blow out the cooling air passage and cylinder fins several times a day.
- Check for proper functioning of the I-O switch, the throttle lever, and the lock button.

Cleaning of air cleaner

- Remove the air cleaner cover.
- Push the choke lever (1) to  position to prevent dirt particles from entering the carburetor.
- Take out the sponge element (2), wash it in lukewarm water and dry it completely.
- After cleaning, put back the air cleaner cover (3).

NOTE: If there is excessive dust or dirt adhering to the air cleaner, clean it every day. A clogged air cleaner may make it difficult or impossible to start the engine increase the engine rotational speed.

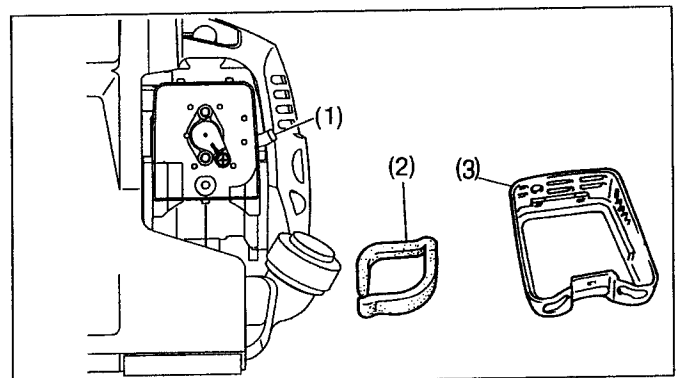
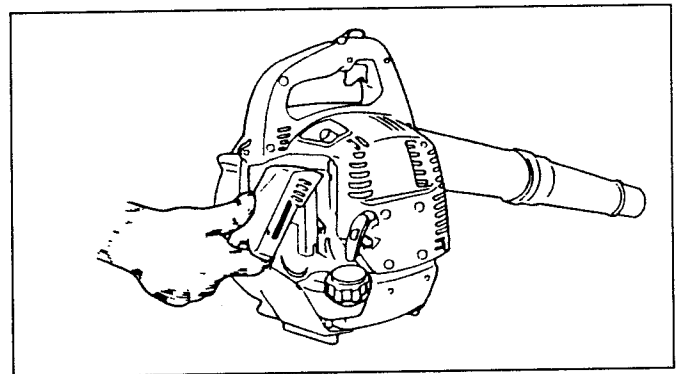

Checking the spark plugs

- Use only the supplied socket wrench to remove or install the spark plug.
- The gap between the two electrodes of the spark plug should be 0.6 – 0.7 mm (0.024" – 0.028"). If the gap is too wide or too narrow, adjust it. If the spark plug is clogged with carbon or fouled, clean it thoroughly or replace it.

CAUTION: Never touch the spark plug connector while engine is running (danger of high voltage electric shock).

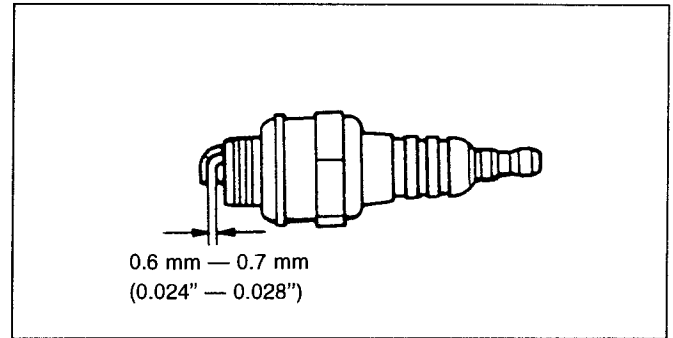

Cleaning of muffler exhaust port

- Check muffler exhaust port (1) regularly.
- If it is clogged with carbon deposits, carefully scrape the deposits out with a suitable tool.

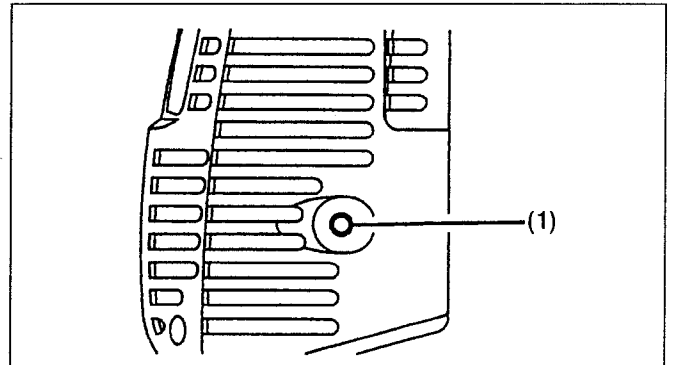

Any maintenance or adjustment work that has not been included and described in this manual is only to be performed by Authorized Service Agent.

Maintenance schedule

General	Engine assembly, screws and nuts	Visual inspection for damage and tightness Check for general condition and security
After each refuelling	Throttle lever I-O switch	Functional check Functional check
Daily	Sponge element (air filter) Cooling air duct Idling speed	To be cleaned To be cleaned Inspection
Weekly	Spark plug Muffler	Inspection, replace if necessary Check and if necessary clean the opening
Quarterly	Suction head (gas line filter) Fuel tank	To be replaced To be cleaned
Storing	Fuel tank Carburetor	Empty fuel tank Operate until engine runs out of fuel

Storage

- When keeping the machine in storage for a long time, drain fuel from the fuel tank and carburetor, as follows : Drain all fuel from the fuel tank. Give a gentle push on the primer pump repeatedly until all fuel is expelled out of the primer pump. Dispose of properly and in accordance with all local laws.
- Remove the spark plugs and add a few drops of oil into each spark plug hole. Then, pull the starter gently. Confirm that oil film covers the engine inside and tighten the spark plugs.
- Clear dirt or dust from outside of engine, wipe them with an oil-immersed cloth and keep the machine locked in a dry, well ventilated location.
- Do not store in a closed area where fuel vapors can reach an open flame from hot water heaters, furnaces etc.

Troubleshooting procedures

Problem	System	Observation	Possible causes
Engine not starting or starts with difficulty	Ignition system	Ignition spark is present	Faulty fuel supply or compression system, mechanical defect
		No ignition spark	STOP-switch operated, wiring fault or short circuit, spark plug or connector defective, ignition module faulty
	Fuel supply	Fuel tank filled	Incorrect choke position, carburetor defective, suction head (gas line filter) dirty, fuel supply line bent or interrupted
	Compression	No compression when pulled over	Cylinder bottom gasket defective, crankshaft seals damaged, cylinder or piston rings defective or improper sealing of spark plug
	Mechanical fault	Starter not engaging	Broken starter spring, broken parts inside of the engine
Warm start problems		Tank filled Ignition spark existing	Choke in incorrect position Carburetor contaminated, have it cleaned
Engine starts but dies immediately	Fuel supply	Tank filled	Incorrect idling adjustment, carburetor contaminated Fuel tank cap defective, fuel supply line interrupted, cable or STOP-switch faulty
Insufficient performance	Several systems may simultaneously be affected	Engine idling	Air filter contaminated, carburetor contaminated, muffler clogged, exhaust duct in the cylinder clogged

Mass (with blower pipes)	Poids (avec tuyau de soufflerie)	Gewicht (mit Bläserrohr)	kg	3.9
-----------------------------	-------------------------------------	-----------------------------	----	-----

Designation of parts

Désignation des pièces

Bezeichnung der Teile

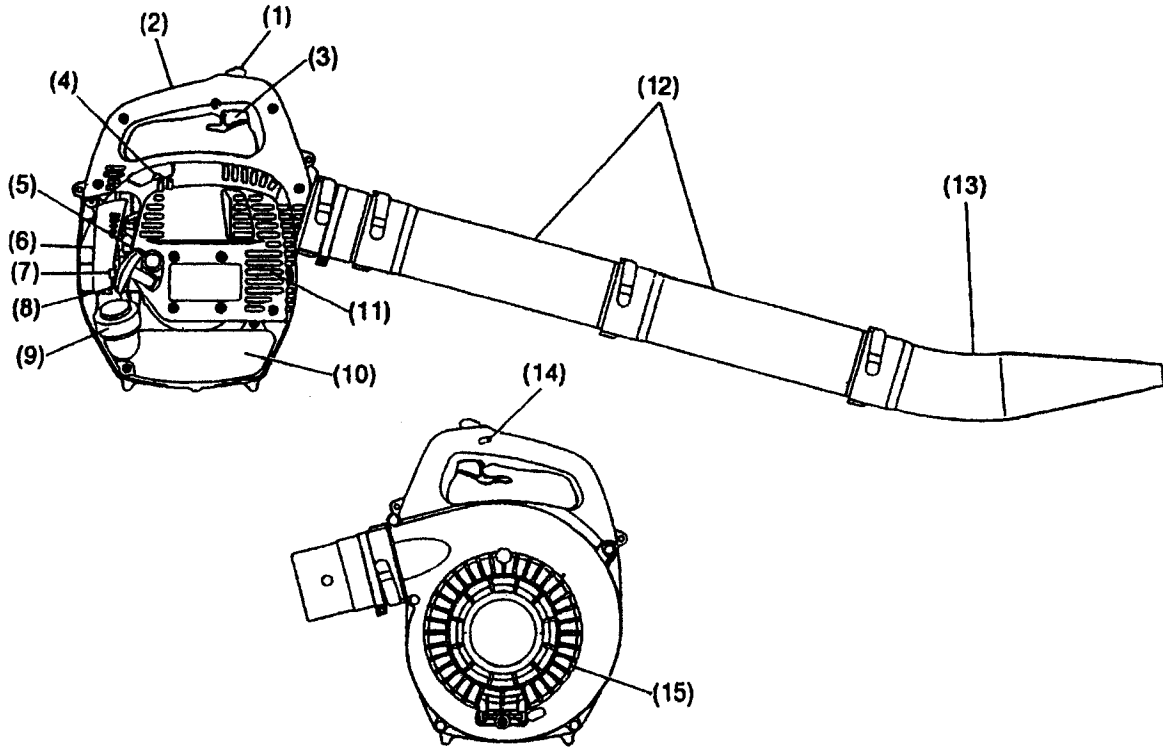

	DESIGNATION OF PARTS		DESIGNATION OF PARTS		DESIGNATION OF PARTS
1	I-O Switch	7	Choke Lever	13	Nozzle
2	Handle	8	Starter Knob	14	Lock Button
3	Throttle Lever	9	Fuel Filler Cap	15	Protector
4	Spark Plug	10	Fuel Tank		
5	Primer Pump	11	Muffler		
6	Air Cleaner	12	Blower Pipe		

	Désignation des pièces		Désignation des pièces		Désignation des pièces
1	Interrupteur	7	Levier de starter	13	Sueur
2	Poignée	8	Bouton de démarreur	14	Touche de blocage
3	Manette des gaz	9	Bouchon du réservoir	15	Protection
4	Bougie	10	Réservoir de carburant		
5	Pompe de carburant	11	Pot d'échappement		
6	Filtre à air	12	Tuyau de soufflerie		

	BEZEICHNUNG DER TEILE		BEZEICHNUNG DER TEILE		BEZEICHNUNG DER TEILE
1	I-O-Schalter	7	Chokehebel	13	Düse
2	Haltegriff	8	Sartergriff	14	Arretlsrknopt
3	Gashebel	9	Kraftstofftankverschluss	15	Schutzhaube
4	Zündkerze	10	Kraftstofftank		
5	Einspritzpumpe	11	Schalldämpler		
6	Luftrfilter	12	Bläserrohr		

Makita Corporation

3-11-8, Sumiyoshi-cho,
Anjo, Aichi 446-8502, Japan