

MICROWAVE

600mm

MWB-23EGX AUS



- 23 Litre Capacity
- 5 level microwave power selector
- 60 minute time selector
- Auto cook, grill and microwave functions
- 1200 watt ultra-fast Quartz Grill
- Stainless Steel

features

specifications

Microwave Capacity:	23 Litres
Microwave Power:	800 Watt
Total Power:	1.3 kW

dimensions

Product Dimensions Width: 592mm Height: 390mm Depth: 400mm

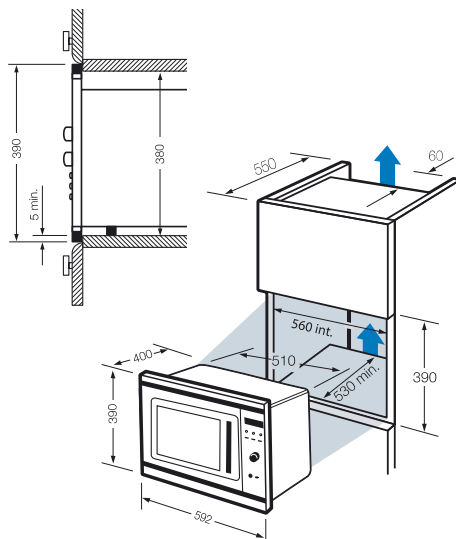

warranty - customer service

Warranty

3 years Parts and Labour

Customer Service

Our Nationwide Service Team can be contacted on our Toll Free Customer Service Number 1800 805 300 or by logging on to <http://customersupport.hapl.com.au/>

Home Appliances
 20 Carlotta Street
 Artarmon NSW 2064
 T: 02 9958 3111
 F: 02 9958 3555
 E: info@hapl.com.au

www.fagorappliances.com.au

